

Fire Ground Hydraulics

15

Section II - Engine Company Operations



Determining Pump Pressure
Hydraulic Calculations
Definitions, Measurements, and Charts
Annual Service Pump Test
Hydraulic Problems



FIREGROUND HYDRAULICS

INTRODUCTION

This section is designed to give pump operators a quick and fairly easy process for determining fire ground hydraulics. Supplying water is a critical part of the control, and the efficient use of this water requires maintaining specified pressures and flow rates. Remember, like everything else there is an acceptable margin of error. If pressures are within 5 or 10 psi of the required psi, little of the effectiveness is lost. Also, gauges are not precise. They vibrate with the engine and two people reading the same gauge will probably read slightly different pressures.

The objective of this section is to enable the pump operator to solve any hydraulic problem within one minute with 100% accuracy. This, together with fire-ground experience, will enable the operator to supply a continuous flow of water at the desired pressure.

OBJECTIVES

- Define pump pressure and energy resistance. Describe sources of energy resistance.
- State the weight of one foot of water and elevation friction loss to the nearest tenth.
- State the friction loss rate formula for specific gpm.
- Describe, in detail, the facts a pump operator must know in order to determine pump pressure.
- State the initial set-up pressures when a request is made for water before hydraulic calculations can be made.
- Calculate pump pressure (**PP**) for a variety of instances.
- Identify the conversion factors to 2 1/2" hose when using other sizes of hose.
- Calculate equivalent flow conversions when converting from 2 1/2" hose to all other sizes of hose used by the San Diego Fire Department.
- Calculate the approximate amount of available water flow at a specific hydrant.
- Describe the specific information needed to set up a relay pumping operation.
- Describe the considerations that should be examined before and during relay pumping operations.
- Calculate pump discharge maximums given the rated capacity, rated pressure, and given pressure.
- Determine, by estimation; water flow availability from specific hydrants.
- Estimate the static water pressure at a given city hydrant.
- Estimate the water capacity for water containers (e.g., Tanks, rooms, etc.)
- Describe considerations that should be made concerning the weight of water and nozzle reaction (i.e., water discharge).
- State the measurements that are specific to determining hydraulic pressure.
- Identify and recognize the gpm flow for nozzles used by the San Diego Fire Department.
- Describe operations necessary to prepare a pumper for a service test, and when and where the test should take place.
- Describe each portion of the service test in detail.

DETERMINING PUMP PRESSURE

PUMP PRESSURE

Pump pressure is the amount of pressure in pounds per square inch (**psi**) indicated on the pressure gauge or any given discharge gauge. Visualize running the pump on a fire engine. You are standing at the pump panel. You are running the throttle out which increases the rpm's of the engine (and thereby the



pump) and you notice the pressure gauge at the pump panel increase from 50 psi to 100 psi. This is energy created by the pump which makes the water move through the plumbing on the fire engine. The pump pressure is telling you the amount of pressure being developed at the discharge side of the pump and up to the discharge outlets on the fire engine.

In fire ground hydraulics the basic pump pressure formula for a level lay is:

Pump Pressure = Nozzle Pressure + Total Friction Loss. This equation is: **PP = NP + TFL**

The pressure registering on the pump pressure gauge will not be the same at the nozzle because energy (pressure) is being used up overcoming friction within the hose. Friction loss is determined by recognizing that water, as a non-compressible fluid, exerts pressure equally against its confining material. Therefore, fluid pressure must be determined as a rate of water flow versus the friction index of the substance it is flowing through. Fortunately, in the case of fire hose, the friction loss rate (**FLR**) is a simple function of the square of the amount of water flowing. Specifically, the total gallons per minute (**gpm**) divided by 100 and then squared and then doubled, has been found to be an adequate fire ground formula for computing the friction loss rate.

$$\text{FLR} = 2Q^2$$

$$\text{Where } Q = \frac{\text{gpm}}{100}$$

DETERMINING PUMP PRESSURE

As a pump operator, you must have certain facts to determine pump pressure (**PP**). These facts are listed in order of importance for calculating the pump pressure:

- ▶ Nozzle Pressure
- ▶ GPM flowing or Size of the nozzles tip
- ▶ Size of hose
- ▶ Length of hose in lay
- ▶ Elevation differential between pump and nozzle
- ▶ Appliance Loss
- ▶ Sprinkler System or Stand Pipe Loss,

The first five facts are needed, in all cases, to solve pump pressure. Make sure you gather these facts and put them on your scratch pad or memory bank.

NOZZLE PRESSURE

The next step in the simplification of fire ground hydraulics is to establish nozzle pressures for all nozzle streams. The San Diego Fire Department has established the following as the desired Nozzle Pressures (**NP**)

<u>NOZZLE PRESSURE</u>	<u>NOZZLE TYPE</u>
50 psi	Hand lines with smooth bore tips 1 ¼" and smaller (Includes Hi-Rise Nozzle with 7/8" Slug Tip)
75 psi	Hi-Rise Nozzle – Fog Nozzle
80 psi	Deluge sets, monitor nozzles, or water tower equipped with smooth bore tips 1 ¼" and larger
100 psi	Adjustable or fog nozzles
100 psi	Foam application

DETERMINING PUMP PRESSURE

GPM FLOWS FOR FOG NOZZLES AND SMOOTH BORE

Fog nozzles have adjustable gpm flows that can be found labeled on the nozzle. The gpm flow depends on the settings used by the firefighter.

When pumping to an adjustable gpm fog nozzle and the gpm setting is **NOT KNOWN**.

- When a hose line is used for an **INTERIOR ATTACK**, use **150 gpm** as your **MAXIMUM** gpm flow.
- When a hose line is used for an **EXTERIOR ATTACK**, use **200 gpm** as your **MAXIMUM** gpm flow.
- When the use and gpm setting are both unknown, pump to the **highest** gpm for that nozzle.
Example: When a 95, 125, 150 and 200 gpm fog nozzle is used, pump to the 200 gpm setting.

Smooth Bore Nozzles. The size of the straight tip nozzle plus pressure determines the gallon per minute flow, which is the major factor causing friction loss in fire hose. The larger the tip or nozzle, at a given nozzle pressure, the more friction loss involved. For any size **SMOOTH BORE** nozzle, the discharge for fresh water can be approximately determined by this formula.

$$\text{GPM} = 30 d^2 \sqrt{NP} \quad \text{Where } d = \text{diameter and } NP = \text{Nozzle Pressure}$$

HINT

There are only two square root numbers to choose from for these calculations.

Hand held straight tip - 50 psi = **7**

Hose Control or Monitor - 80 psi = **9**

See Nozzle Pressures section.

DETERMINING PUMP PRESSURE

GPM FLOWS FOR SMOOTH BORE (Continued)

After calculating **nozzle gpm** it is necessary to round off. **Round off** according to the following rules:

- **Handheld** (NP = 50) smooth bore tips $\frac{1}{4}$ " to $\frac{3}{8}$ ", to the **NEAREST 1** gpm

- **Handheld** (NP = 50) smooth bore tips $\frac{1}{2}$ " to $1 \frac{1}{4}$ ", to the **NEAREST 10** gpm

- **Appliances** (NP = 80) $1 \frac{1}{4}$ " to 2", to the **NEAREST 100** gpm

A list of nozzles with their respective gpm is presented near the end of this section.

SIZE OF HOSE

The size of hose and gpm flowing determine the amount of friction loss for each 100-foot section. With a given flow, the smaller the diameter, the more friction loss involved. This is because a greater proportion of the water pushed through actually comes into contact with the interior surface of the hose than in the case of a larger hose. A larger diameter hose allows a relatively larger percentage of the water volume to go through without contacting the interior surface.

DETERMINING PUMP PRESSURE

SIZE OF HOSE (Continued)

Fire hose is limited in the amount of pressure it can sustain. Because of this, the maximum pressure we can pump to any given hose is it's annual service test pressure.

The maximum Pump Pressure for fire hose is:

TYPE	SIZE	COLOR	SERVICE PRESSURE & MAXIMUM PUMP PRESSURE
Booster Line	¾" and 1"	RED	400 PSI
Cotton Single Jacket (Wildland)	1" and 1 ½"	YELLOW	300 PSI
Synthetic Double Jacket (Attack Line)	1", 1 ¾", 2 ½", 3, & 4"	YELLOW	300 PSI
Synthetic Double Jacket (High Pressure)	2 ½", 3"	BLUE GREEN	600 PSI
Hard Suction	4"	BLACK	150 PSI

REMEMBER: When pumping through a combination of hoses, the lowest pressure hose is the determining factor for maximum pump pressure.

DETERMINING PUMP PRESSURE

EQUIVALENT FLOWS

The first step is to determine the actual number of gallons per minute flowing through the size of hose used in the lay. This is a function of the nozzle used and the pressure supplied at the nozzle.

The formula for determining friction loss rate (**FLR = 2Q²**) is based on gpm through 2 1/2" hose.

All flow rates through various size hoses must be converted to an equivalent flow (**EF**) as if it were flowing through 2 1/2" hose.

Converting gpm flow in other than 2 1/2" hose to equivalent flow of 2 1/2" hose

To calculate friction loss in hose other than 2 1/2", we have developed factors to convert the larger and smaller hose flows to gpm flow that creates the same amount of friction loss as in 2 1/2" hose.

These factors are based on comparison of friction in hose other than 2 1/2" to that of 2 1/2" hose

CONVERSION FACTORS TO 2 1/2" HOSE	
HOSE SIZE	CONVERSION FACTOR
3/4"	25
1"	9
1 1/2"	3.6
1 3/4"	2
3"	.67
3 1/2"	.4
4"	.25

DETERMINING PUMP PRESSURE

EQUIVALENT FLOWS

When converting:

- ¾" hose to equivalent flow of 2 ½" hose. Multiply gpm flow from ¾" hose by **25**.
- 1" hose to equivalent flow of 2 ½" hose. Multiply gpm flow from 1" hose by **9**.
- 1 ½" hose to equivalent flow of 2 ½" hose. Multiply gpm flow from 1 ½" hose by **3.6**.
- 1 ¾" hose to equivalent flow of 2 ½" hose. Multiply gpm flow from 1 ¾" hose by **2.0**.
- 3" hose to equivalent flow of 2 ½" hose. Multiply gpm flow from 1 ¾" hose by **.67**
- 3 ½" hose to equivalent flow of 2 ½" hose. Multiply gpm flow from 3 ½" hose by **.4**.
- 4" hose to equivalent flow of 2 ½" hose. Multiply gpm flow from 4" hose by the factor **.25**.

After the flow is computed it is treated as a 2 ½" hose, this flow is rounded off as 2 ½" hose to the NEAREST 10 gpm.

LENGTH OF HOSE IN LAY

In order to solve the amount of friction loss in a hose lay you must know the entire length of the hose lay. Friction loss rate factors are computed on 100' lengths of hose. When hose is doubled, as in the case of a siamese lay, it is necessary to average the lengths. This procedure will be described later. Remember: $L = \text{total length of hose in feet divided by } 100$.

$$L = \frac{\text{total feet}}{100}$$

DETERMINING PUMP PRESSURE

ELEVATION DIFFERENTIAL BETWEEN PUMP AND NOZZLE

Elevation differential is also called head, gravity loss or gravity gain. When hose lines are laid up or down an elevation, such as inclines, stairways, fire escapes, canyons, or the face of a building, the pressure loss or gain in pounds per square inch, which is exerted by the head of water, must be compensated for. If energy (pressure) is gained by water going down then you must subtract head. If energy (pressure) is lost by pushing water up then you must add head.

Head is the height of water. One foot of head is equivalent to a column of water one-foot high. Head becomes pressure because a column of water one foot high by one square inch weighs .434 pounds. **For fire ground hydraulics this weight has been rounded to .5 pounds.** The pressure is proportional to the height of the liquid column alone, and not to the size or shape of the vessel.

Head is very much like climbing up or down a ladder. As you climb up a ladder you must exert strength (pressure) in your legs and arms to reach the desired elevation. When descending a ladder gravity exerts a pull upon your body. If you lost your footing and fell, your body would gain tremendous downward pressure. The amount of pressure developed would determine the force of impact. The longer the fall in elevation, the greater the pressure.

Energy (pressure) is used up when pumping water higher than the pump. **Water weighs 8.35 pounds per gallon** and the effort of lifting this weight uses up some of the engine pressure. It takes .434 psi to lift water one foot. For fireground hydraulics this figure has been rounded off to **.5 psi**.

Just as it takes energy to lift water, energy is gained by dropping water. In fact, an equal **.434 psi** is gained in energy for every one-foot water drops in elevation. For fireground hydraulics this figure has been rounded off to **.5 psi**.

When calculating the Gravity Loss in a high rise building calculate 5 pounds per floor.

DETERMINING PUMP PRESSURE

ELEVATION DIFFERENTIAL BETWEEN PUMP AND NOZZLE

REMEMBER

Gravity Loss (GL) - **ADD** Pressure

Gravity Gain (GG) - **SUBTRACT** Pressure

INITIAL PUMP PRESSURE

Often a pump operator will get the request for water before accurate hydraulic calculations can be made. In this situation the standard operating procedure will be to pump the pressures given below for the following cases:

- **ALL HAND LINES:** Initial Pump Pressure = **NOZZLE PRESSURE + GL or – GG**
 - **ELEVATED STREAMS:** Initial Pump Pressure = **150** psi
 - **SPRINKLER and STANDPIPE SYSTEMS:** Initial Pump Pressure = **150** psi.
-

HYDRAULIC SET-UPS AND CALCULATIONS

EXAMPLE OF FIRE GROUND HYDRAULICS AND WRITTEN HYDRAULICS

NOTE: RULES WILL HAVE AN ASTERISKS (*) AND BE UNDERLINED

The following example will show how fire ground hydraulics is tied directly to written hydraulics:

250 gpm SOF nozzle, 250 gpm setting, 450' of 2 1/2" hose, PP = ?

Initial pump pressure = 100 psi

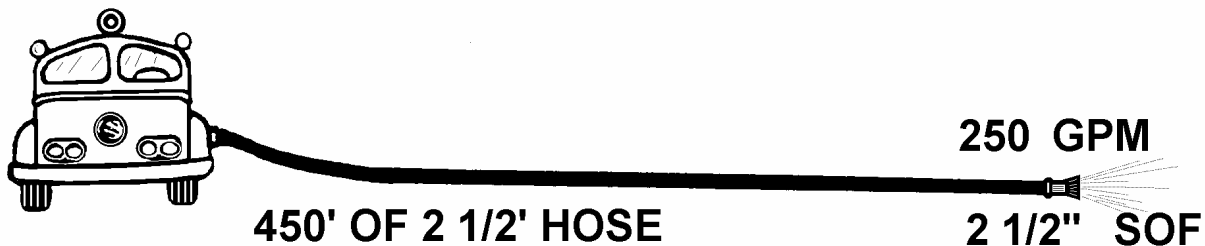

In fire ground hydraulics the pump pressure formula for a level lay is:

$$\underline{PP = NP + TFL}$$

$$TFL = FLR \times L$$

$$FLR = 2Q^2$$

$$Q = \frac{GPM}{100}$$

Working this out step-by-step would look like this:

- **Step One:** Determine the **Nozzle Pressure (NP)** for a fog nozzle. **NP = 100 psi**
- **Step Two:** Determine the **GPM Flow = 250 gpm**

HYDRAULIC SET-UPS AND CALCULATIONS

EXAMPLE OF FIRE GROUND HYDRAULICS AND WRITTEN HYDRAULICS

➤ **Step Three:** Calculate the Friction Loss Rate (FLR)

$$FLR = 2Q^2$$

$$FLR = 2 \frac{(gpm)^2}{100}$$

$$FLR = 2 \frac{(250)^2}{100} = 2.5$$

$$FLR = 2(2.5)^2$$

$$FLR = 2 \times 6.25 = 12.5$$

Round off 12.5 to 13

$$FLR = 13 \text{ psi}$$

HINT

For 2 ½" flows between **180 & 320** subtract **12** from the first 2 numbers.

(250 - 12 = 13)

See friction loss table in appendix

HINT

Squaring a .5 number such as (2.5), subtract .5 from one 2.5 and add .5 to the other.

$$2.5 - .5 = 2 \qquad 2.5 + .5 = 3$$

In this example it would give you the numbers 2 and 3.

Multiply 2 x 3 = 6 - Now Add .25

Answer 6.25

➤ **Step Three:** Determine Length (L) of the hose

$$L = \frac{\text{total feet}}{100}$$

$$L = \frac{450}{100}$$

$$L = 4.5$$

➤ **Step Four:** Calculate Total Friction Loss (TFL)

$$TFL = FLR \times L$$

$$TFL = 13 \times 4.5 = 58.5$$

Round off 58.5 to 59

$$TFL = 59 \text{ psi}$$

Finally: Add together the Nozzle Pressure and Total Friction Loss to equate the Pump Pressure.

$$PP = NP + TFL$$

$$PP = 100 + 59$$

$$PP = 159 \text{ psi}$$

HYDRAULIC SET-UPS AND CALCULATIONS

Hand lines - Straight Lay – Smooth Bore Tip

Example: 1" tip, 650' of 2 ½" hose, PP =?

Initial pump pressure = 50 psi

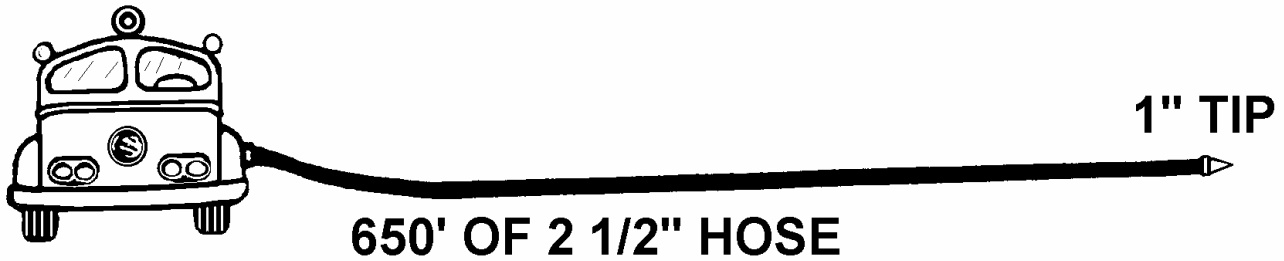

➤ Step One: NP = 50 psi.

➤ Step Two: $GPM = 30d^2\sqrt{NP}$
 $GPM = 30 \times 1^2 \times \sqrt{50}$
 $GPM = 30 \times 1 \times 7$
 $GPM = \mathbf{210}$

➤ Step Three: $FLR = 2Q^2$
 $FLR = 2 \frac{(gpm)^2}{100}$
 $FLR = 2 \frac{(\mathbf{210})^2}{100} = 2.1$
 $FLR = 2 \times (2.1)^2$
 $FLR = 2 \times 4.41$
 $FLR = 8.82$, round to nearest one psi = **9 psi**

HINT

For 2 ½" flows between **180 & 320** subtract **12** from the first 2 numbers.

(210 - 12 = 9)

See friction loss table in appendix

HYDRAULIC SET-UPS AND CALCULATIONS

Hand lines - Straight Lay – Smooth Bore Tip

➤ **Step Four:** $L = \frac{\text{total feet}}{100}$

$$L = \frac{650}{100}$$

$$L = \mathbf{6.5}$$

➤ **Step Five:** $TFL = FLR \times L$

$$TFL = 9 \times 6.5$$

$$TFL = 58.5 \text{ round to nearest one psi} = \mathbf{59 \text{ psi}}$$

$\begin{aligned} PP &= NP + TFL \\ PP &= 50 + 59 \\ \underline{PP} &= \mathbf{109 \text{ psi}} \end{aligned}$

HYDRAULIC SET-UPS AND CALCULATIONS

Hand lines - Gravity Loss

Example: 2 1/2" SOF nozzle, 250 gpm setting, 600' of 2 1/2" hose, nozzle 40' Above pump level, PP = ?

$$\text{Initial Pump Pressure} = \text{NP} + \text{GL}$$

$$\text{IPP} = 100 + 20 = \text{120 psi}$$

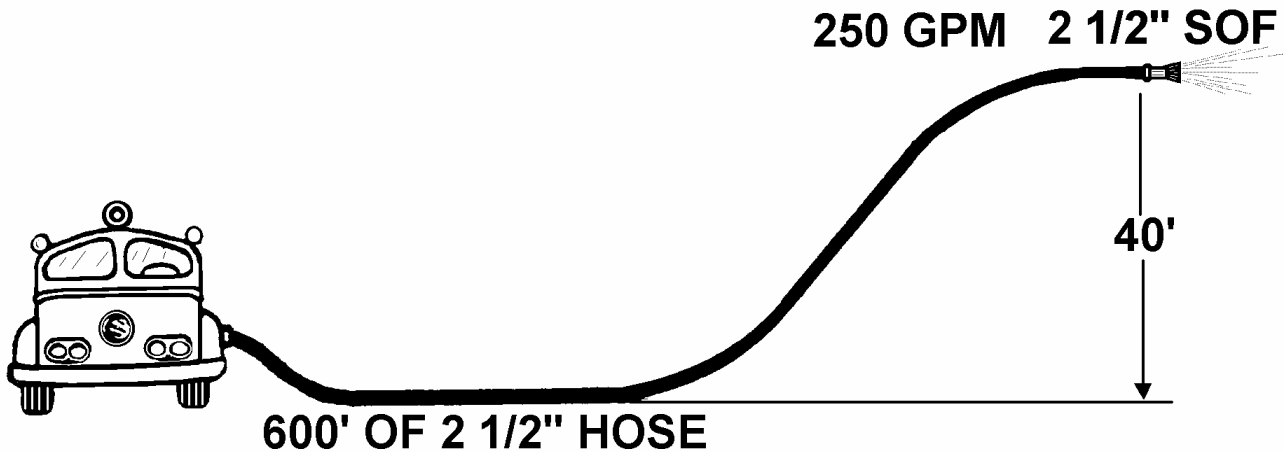

➤ **Step One:** Flow = 250 gpm

➤ **Step Two:** $\text{FLR} = 2Q^2$

$$\text{FLR} = 2 \frac{(\text{gpm})^2}{100}$$

$$\text{FLR} = 2 \frac{(250)^2}{100} = 2.5$$

$$\text{FLR} = 2(2.5)^2$$

$$\text{FLR} = 2 \times 6.25 = 12.5$$

Round off 12.5 to 13

$$\text{FLR} = \text{13 psi}$$

HINT

For 2 1/2" flows between **180 & 320** subtract **12** from the first 2 numbers.

$$(250 - 12 = 13)$$

See friction loss table in appendix

HINT

Squaring a .5 number such as (2.5), subtract .5 from one 2.5 and add .5 to the other.

$$2.5 - .5 = 2$$

$$2.5 + .5 = 3$$

In this example it would give you the numbers 2 and 3.

Multiply $2 \times 3 = 6$, now Add .25

Answer **6.25**

HYDRAULIC SET-UPS AND CALCULATIONS

Hand lines - Gravity Loss

GRAVITY LOSS OR GRAVITY GAIN, ALLOW .5 PSI FOR EACH VERTICAL FOOT OF ELEVATION*

➤ **Step Three:** $L = \frac{\text{total feet}}{100}$

$$L = \frac{600}{100}$$

$$L = 6$$

➤ **Step Four:** $TFL = FLR \times L$

$$TFL = 13 \times 6 = 78$$

$$TFL = \mathbf{78 \text{ psi}}$$

➤ **Step Five:** $*GL = .5 \times H$

$$GL = .5 \times 40 = 20$$

$$GL = \mathbf{20 \text{ psi}}$$

HINT

Multiplying a .5 number is the same as halving or dividing by 2.
($40 \div 2 = 20$)

$$\begin{aligned} \mathbf{PP} &= \mathbf{NP} + \mathbf{TFL} + \mathbf{GL} \\ \mathbf{PP} &= \mathbf{100} + \mathbf{78} + \mathbf{20} \\ \mathbf{PP} &= \mathbf{198 \text{ psi}} \end{aligned}$$

HYDRAULIC SET-UPS AND CALCULATIONS

Hand lines - Gravity Gain

Example: 1 1/8" tip, 500' of 2 1/2" hose, nozzle 30' below the pump level, PP =?

Initial pump pressure = NP - GG

$$\text{IPP} = 50 - 15 = 35 \text{ psi}$$

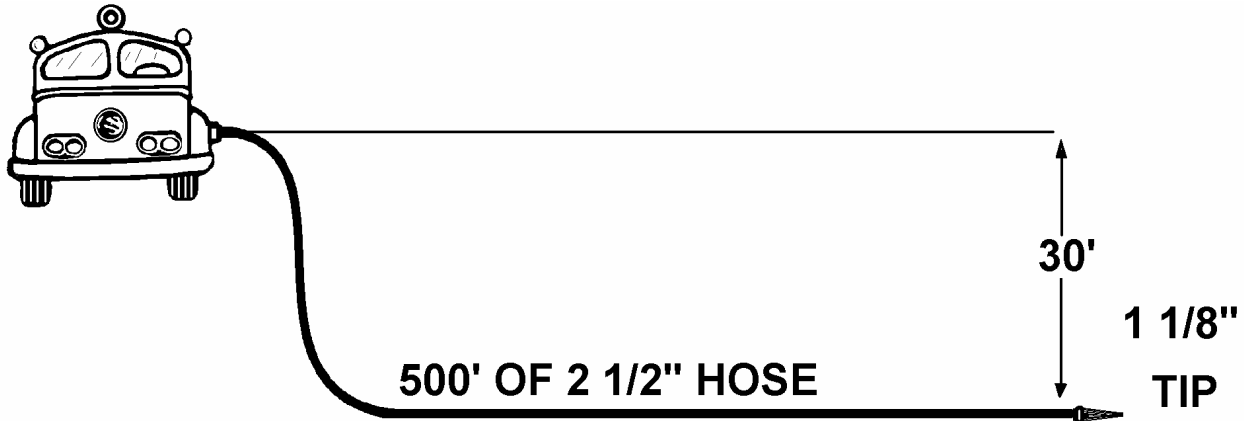

- **Step One:** 1-1/8" tip @ 50 psi
 - $30 d^2 \sqrt{NP}$
 - $30 (1.125)^2 7$
 - $30 \times 1.265 \times 7 = 265.78$
 - Round 265.78 to 270
 - Flow = **270 gpm**

HINT

To convert a fraction to a decimal: divide the numerator by the denominator.

$1 \div 8 = .125$

- **Step Two:** $FLR = 2Q^2$
 - $FLR = 2 \frac{(gpm)^2}{100}$
 - $FLR = 2 \frac{(270)^2}{100} = 2.7$
 - $FLR = 2(2.7)^2$
 - $FLR = 2 \times 7.29 = 14.58$
 - Round off 14.58 to 15
 - FLR = **15 psi**

HINT

For 2 1/2" flows between **180 & 320** subtract **12** from the first 2 numbers.

$(270 - 12 = 15)$

See friction loss table in appendix

HYDRAULIC SET-UPS AND CALCULATIONS

Hand lines - Gravity Gain

GRAVITY LOSS OR GRAVITY GAIN, ALLOW .5 PSI FOR EACH VERTICAL FOOT OF ELEVATION.*

➤ **Step Three:** $L = \frac{\text{total feet}}{100}$

$$L = \frac{500}{100}$$

$$L = 5$$

➤ **Step Four:** $TFL = FLR \times L$

$$TFL = 15 \times 5 = 75 \text{ psi}$$

➤ **Step Five:** $*GG = .5 \times H$

$$GG = .5 \times 30 = 15$$

$$GG = 15 \text{ psi}$$

HINT

Multiplying a .5 number is the same as halving or dividing by 2.
($30 \div 2 = 15$)

$$\begin{aligned} PP &= NP + TFL - GG \\ PP &= 50 + 75 - 15 \\ PP &= 110 \text{ psi} \end{aligned}$$

HYDRAULIC SET-UPS AND CALCULATIONS

Hand lines – 1 3/4" Hose

CONVERTING 1 3/4" HOSE FLOW TO EQUIVALENT FLOW FROM 2 1/2" HOSE. MULTIPLY GPM FLOW FROM 1 3/4" HOSE BY FACTOR 2.*

Example: 1 3/4" SOF nozzle, 200' of 1 3/4" hose, nozzle set at 125 gpm.

Initial pump pressure - NP = 100

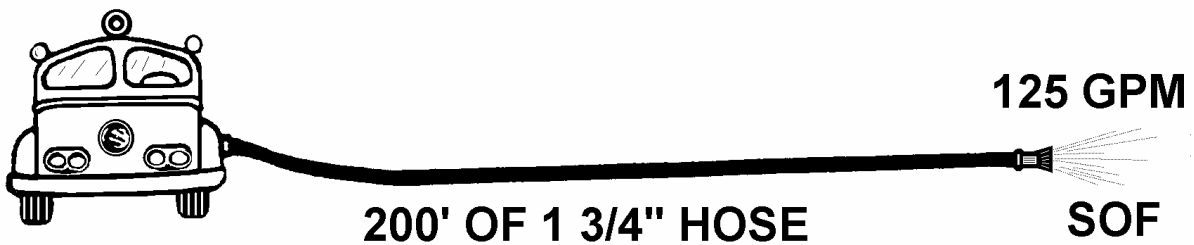

➤ **Step One:** Flow = 125 gpm

*EF = Factor x gpm

EF for 1 3/4" hose = 2 x 125

EF = **250** gpm

➤ **Step Two:** FLR = $2Q^2$

$$FLR = 2 \frac{(gpm)^2}{100}$$

$$FLR = 2 \frac{(250)^2}{100} = 2.5$$

$$FLR = 2(2.5)^2$$

$$FLR = 2 \times 6.25 = 12.5$$

Round off 12.5 to 13

FLR = **13** psi

HINT

For 2 1/2" flows between **180 & 320** subtract **12** from the first 2 numbers.

$$(250 - 12 = 13)$$

See friction loss table in appendix

HINT

Squaring a .5 number such as (2.5), subtract .5 from one 2.5 and add .5 to the other.

$$2.5 - .5 = 2$$

$$2.5 + .5 = 3$$

In this example it would give you the numbers 2 and 3.

Multiply 2 x 3 = 6, now Add .25

Answer **6.25**

HYDRAULIC SET-UPS AND CALCULATIONS

Hand lines – 1 ¾” Hose

➤ **Step Three:** $L = \frac{\text{total feet}}{100}$

$$L = \frac{200}{100}$$

$$L = 2$$

➤ **Step Four:** $TFL = FLR \times L$

$$TFL = 13 \times 2 = 26$$

$$TFL = \mathbf{26 \text{ psi}}$$

$\begin{aligned} PP &= NP + TFL \\ PP &= 100 + 26 \\ \underline{PP} &= \underline{126 \text{ psi}} \end{aligned}$

HYDRAULIC SET-UPS AND CALCULATIONS

Hand lines – Multiple 1 3/4" Hose lines

PUMP TO THE HIGHEST LINE AND GATE DOWN THE SECOND LINE *

Example: Two 1 3/4" hand lines, one 200' and 175 gpm, the second is 150' and 150 gpm.

Initial pump pressure - NP = 100

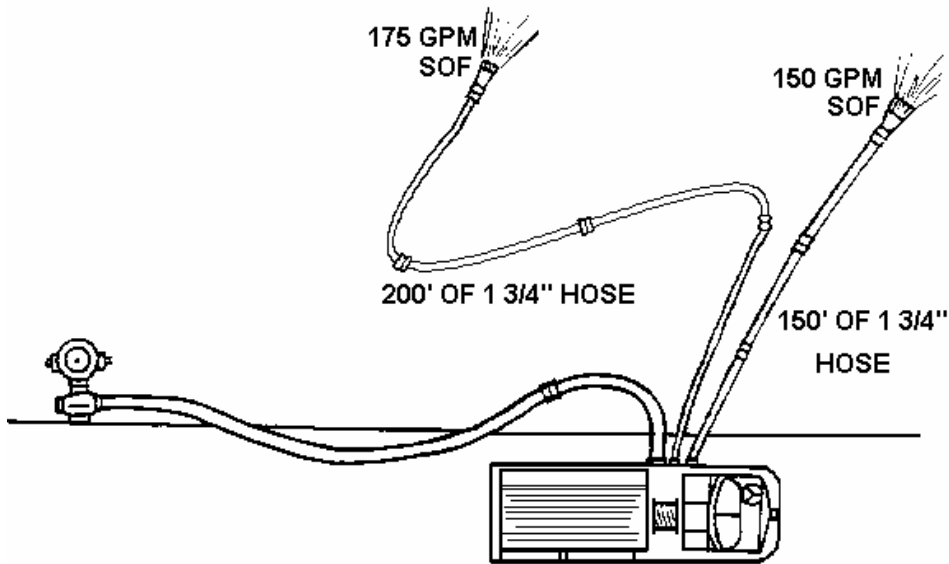

➤ **Step One:** EF = Factor x gpm

Flow (a) = **175** gpm

EF (a) for 1 3/4" hose = 2 x 175 = 350

EF (a) = **350** gpm

Flow (b) = **150** gpm

EF (b) for 1 3/4" hose = 2 x 150 = 300

EF (b) = **300** gpm

➤ **Step Two:** FLR = $2Q^2$

$$FLR = 2 \frac{(gpm)^2}{100}$$

$$FLR = 2 \frac{(350)^2}{100} = 3.5$$

$$FLR (a) = 2(3.5)^2$$

$$FLR (a) = 2 \times 12.25 = 24.5$$

Round off 24.5 to 25

$$FLR (a) = \mathbf{25}$$

$$FLR = 2 \frac{(gpm)^2}{100}$$

$$FLR = 2 \frac{(300)^2}{100} = 3$$

$$FLR (b) = 2(3)^2$$

$$FLR (b) = 2 \times 9 = 18$$

$$FLR (b) = \mathbf{18}$$

HYDRAULIC SET-UPS AND CALCULATIONS

Hand lines – Multiple 1 3/4” Hose lines

HINT

Squaring a .5 number such as (3.5), subtract .5 from one 3.5 and add .5 to the other.

$3.5 - .5 = 3$ $3.5 + .5 = 4$

In this example it would give you the numbers 3 and 4.

Multiply $3 \times 4 = 12$, now Add .25

Answer **12.25**

HINT

For 2 1/2” flows between **180 & 320** subtract **12** from the first 2 numbers.

(300 – 12 = 18)

See friction loss table in appendix

➤ **Step Three:** $L = \frac{\text{total feet}}{100}$

$$L (a) = \frac{200}{100}$$

$$L (b) = \frac{150}{100}$$

$$L (a) = 2$$

$$L (b) = 1.5$$

➤ **Step Four:** $TFL = FLR \times L$

* 1st Pressure (a)

* 2nd Pressure (b) (Gated Down)

$$TFL = 25 \times 2 = 50$$

$$TFL = 18 \times 1.5 = 27$$

$$TFL = 50 \text{ psi}$$

$$TFL = 27 \text{ psi}$$

PP = NP + TFL

(a) $PP = 100 + 50$ (b) $PP = 100 + 27$
***PP = 150 psi** **2nd or GP = 127**

(a) **Pump Pressure = 150**

(b) **Gated Pressure = 127 psi**

HYDRAULIC SET-UPS AND CALCULATIONS

Hand lines – 1 3/4" Hose – Structure Progressive Lay

Example: 150' of 1 3/4" hose with 95 gpm SOF, - **ADD** 150' of 1 3/4" hose. PP = ?

Initial pump pressure - NP = **100**

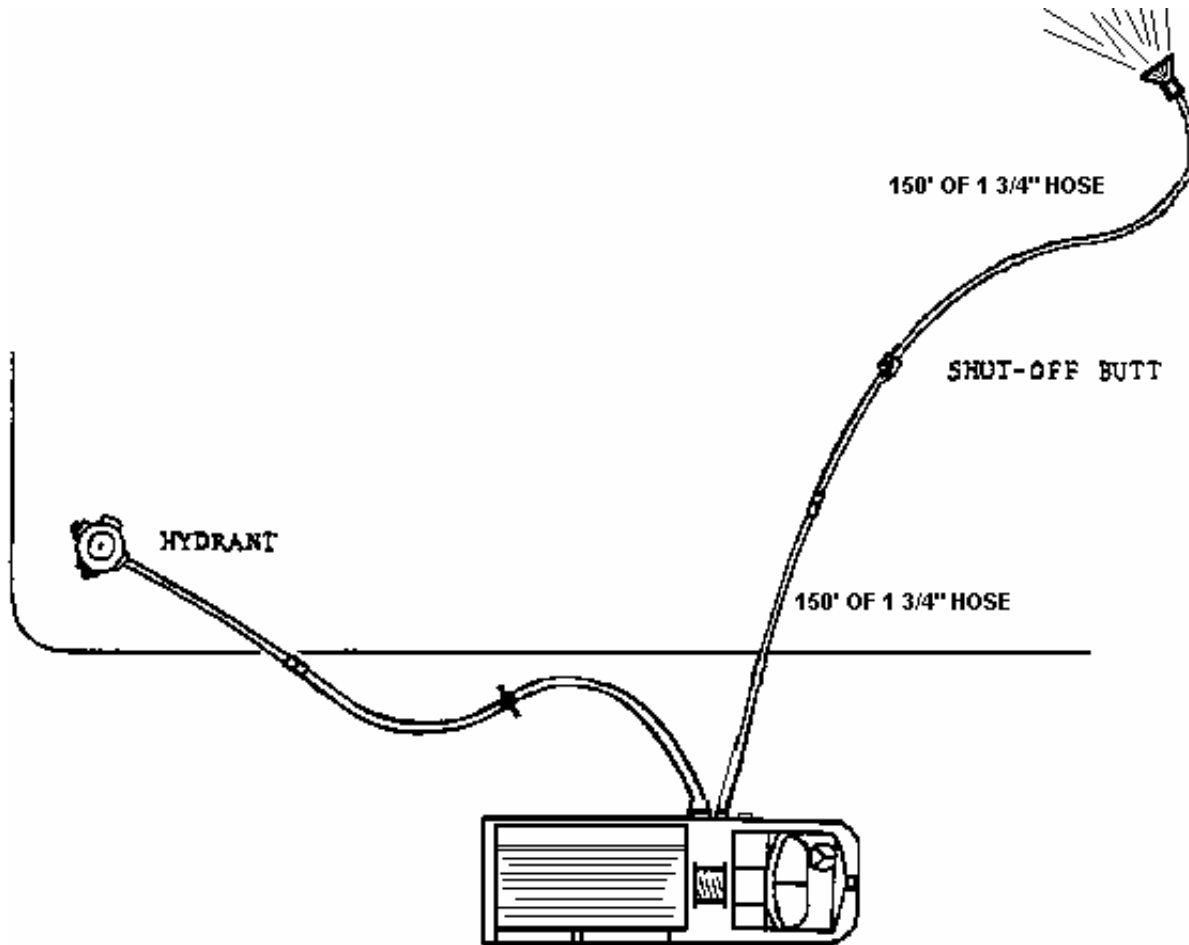

- **Step One:** Flow = **95** gpm
 - *EF = Factor x gpm
 - EF for 1 3/4" hose = 2.0 x 95
 - EF = **190** gpm

HYDRAULIC SET-UPS AND CALCULATIONS

Hand lines – 1 3/4” Hose – Structure Progressive Lay

- **Step Two:** $FLR = 2Q^2$

$$FLR = 2 \frac{(gpm)^2}{100}$$

$$FLR = 2 \frac{(190)^2}{100} = 1.9$$

$$FLR = 2(1.9)^2$$

$$FLR = 2 \times 3.61 = 7.22$$

Round off 7.22 to 7

$$FLR = 7 \text{ psi}$$

HINT

For 2 1/2” flows between **180 & 320** subtract **12** from the first 2 numbers.

(190 – 12 = 7)

See friction loss table in appendix

- **Step Three:** $L = \frac{\text{total feet}}{100}$

$$L = \frac{150}{100}$$

First L = **1.5**

With Second line added, L = 3

- **Step Four:** $TFL = FLR \times L$

First TFL = 7 x 1.5 = 10.5

Round off 10.5 to 11

TFL = 11

Second TFL (line added) = 7 x 3 = 21

TFL = 21

PP = NP + TFL

PP#1 = 100 + 11	PP#2 = 100 + 21
<u>PP #1 = 111 psi</u>	<u>PP #2 = 121 psi</u>

HYDRAULIC SET-UPS AND CALCULATIONS

Hand lines – 1 1/2" Hose

CONVERTING 1 1/2" HOSE FLOW TO EQUIVALENT FLOW FROM 2 1/2" HOSE. MULTIPLY GPM FLOW FROM 1 1/2" HOSE BY FACTOR 3.6.*

Example: 3/8" straight tip, 800' of 1 1/2" hose. PP =?

Initial pump pressure - NP = 50

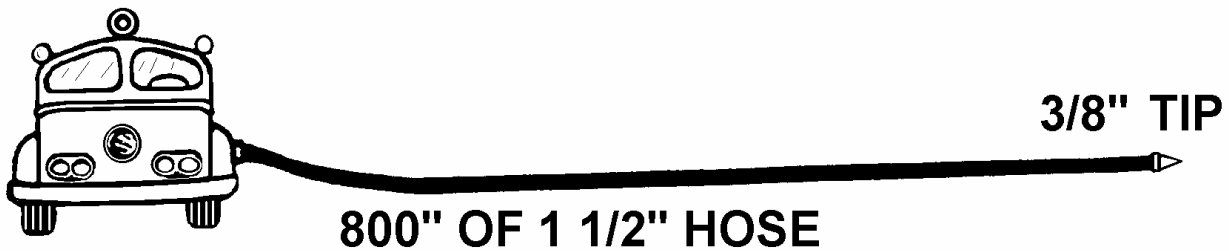

➤ **Step One:** 3/8" tip @ 50 psi

$$30 d^2 \sqrt{NP}$$

$$30 \times (.375)^2 \times 7$$

$$30 \times .141 \times 7 = 29.61$$

Round off 28.61 to 30

Flow = **30 gpm**

HINT

To convert a fraction to a decimal: divide the numerator by the denominator.

$$3 \div 8 = .375$$

OR

$$30 \times d^2 \times \sqrt{NP}$$

$$\frac{30 \times 3 \times 3 \times 7}{1 \times 8 \times 8 \times 1 \times 64} = \frac{1890}{64} = 29.53 = 30 \text{ gpm}$$

*EF = Factor x gpm

EF for 1 1/2" hose = 3.6 x 30 = 108

EF = **110 gpm**

HINT

Convert and round off to the nearest 10 gpm.

HYDRAULIC SET-UPS AND CALCULATIONS

Hand lines – 1 ½” Hose

➤ **Step Two:** $FLR = 2Q^2$

$$FLR = 2 \frac{(\text{gpm})^2}{100}$$

$$FLR = 2 \frac{(110)^2}{100} = 1.1$$

$$FLR = 2(1.1)^2$$

$$FLR = 2 \times 1.21$$

$$FLR = 2.42$$

$$FLR = 2 \text{ psi}$$

➤ **Step Three:** $L = \frac{\text{total feet}}{100}$

$$L = \frac{800}{100}$$

$$L = 8$$

➤ **Step Four:** $TFL = FLR \times L$

$$TFL = 2 \times 8 = 16 \text{ psi}$$

$PP = NP + TFL$ $PP = 50 + 16$ $PP = 66 \text{ psi}$
--

HYDRAULIC SET-UPS AND CALCULATIONS

Hand lines – 1” Hose

CONVERTING 1" HOSE FLOW TO EQUIVALENT FLOW FROM 2 1/2" HOSE. MULTIPLY GPM FLOW FROM 1" HOSE BY FACTOR 9.*

Example: 1" SOF nozzle, 24 gpm, and 250' of 1" hose, PP =?
Initial pump pressure = 100 psi

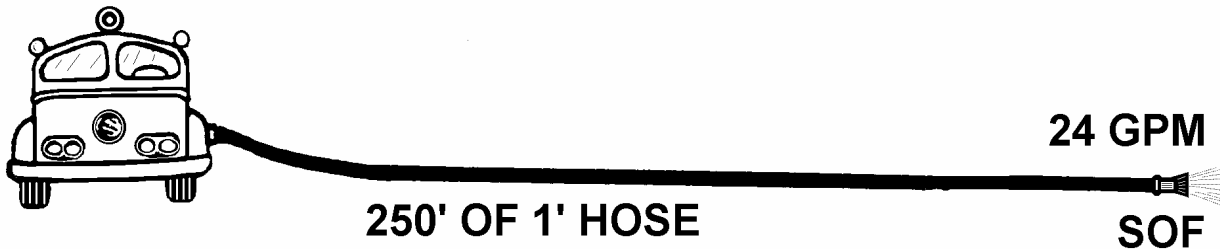

➤ **Step One:** Flow = 24 gpm

*EF = Factor x gpm

EF for 1" hose = 9 x 24 = 216

Round off 216 to 220

EF = **220** gpm

HINT

Convert and round off to the nearest 10 gpm.

➤ **Step Two:** FLR = $2Q^2$

$$FLR = 2 \frac{(gpm)^2}{100}$$

$$FLR = 2 \frac{(220)^2}{100} = 2.2$$

$$FLR = 2(2.2)^2$$

$$FLR = 2 \times 4.84 = 9.68$$

Round 9.68 off to 10

FLR = **10** psi

HINT

For 2 1/2" flows between **180 & 320** subtract **12** from the first 2 numbers.

(220 - 12 = 10)

See friction loss table in appendix

HYDRAULIC SET-UPS AND CALCULATIONS

Hand lines – 1” Hose

➤ **Step Three:** $L = \frac{\text{total feet}}{100}$

$$L = \frac{250}{100}$$

$$L = 2.5$$

➤ **Step Four:** $TFL = FLR \times L$

$$TFL = 10 \times 2.5 = 25$$

$$TFL = 25$$

$$PP = NP + TFL$$

$$PP = 100 + 25$$

$$PP = \underline{125 \text{ psi}}$$

HYDRAULIC SET-UPS AND CALCULATIONS

Hand lines – Red line

CONVERTING 3/4" AND 1" HOSE FLOW TO EQUIVALENT FLOW FROM 2 1/2" HOSE: MULTIPLY GPM FLOW FROM 3/4" HOSE BY FACTOR 25 and 1" HOSE BY FACTOR 9.*

Example: 1" SOF nozzle, 24 gpm, and 100' of 1" and 150' of 3/4" hose PP =?

Initial pump pressure = 100 psi

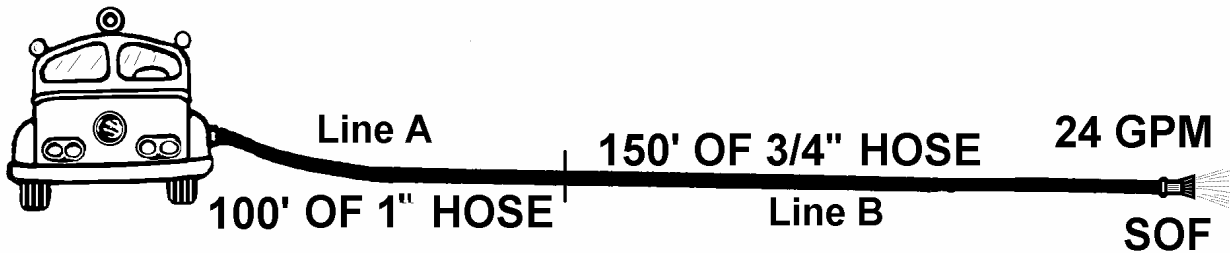

A

B

➤ **Step One:** Flow = 24 gpm

*EF = Factor x gpm

FLOW THROUGH 1"

EF(a) = 9 x 24 = 216

Round off 216 to 220

EF(a) for 1" hose = **220** gpm

FLOW THROUGH 3/4"

EF(b) = 25 x 24 = 600

EF(b) for 3/4" hose = **600** gpm

➤ **Step Two:** FLR = $2Q^2$

$$FLR = 2 \frac{(gpm)^2}{100}$$

$$FLR = 2 \frac{(220)^2}{100} = 2.2$$

$$FLR(a) = 2(2.2)^2$$

$$FLR(a) = 2 \times 4.84 = 9.68$$

Round 9.68 off to 10

$$FLR(a) = \mathbf{10} \text{ psi}$$

$$FLR = 2 \frac{(gpm)^2}{100}$$

$$FLR = 2 \frac{(600)^2}{100} = 6$$

$$FLR(b) = 2(6)^2$$

$$FLR(b) = 2 \times 36$$

$$FLR(b) = \mathbf{72} \text{ psi}$$

HYDRAULIC SET-UPS AND CALCULATIONS

Hand lines – Red line

HINT

For 2 ½” flows between
180 & 320 subtract **12**
from the first 2 numbers.

(220 – 12 = 10)

See friction loss table in
appendix

➤ **Step Three:** $L = \frac{\text{total feet}}{100}$

$$L = \frac{100}{100}$$

$$L(a) = 1$$

$$L = \frac{150}{100}$$

$$L(b) = 1.5$$

➤ **Step Four:** $TFL = FLR(a) \times L + FLR(b) \times L$

$$1" \text{ hose } FL(a) = 10 \times 1 = 10$$

$$\frac{3}{4}" \text{ hose } FL(b) = 72 \times 1.5 = 108$$

$$TFL = 10 + 108 = 118$$

PP = NP + TFL
PP = 100 + 118
PP = 218 psi

HYDRAULIC SET-UPS AND CALCULATIONS

Siamese Lines (Equal Length)

FOR EQUAL SIAMESE LINES DIVIDE FLOW AND CALCULATE FOR ONE LINE.*

Example: 1 1/8" tip, 50 psi NP, two 400' lines of 2 1/2" hose into one 100' line of 2 1/2" hose.

PP = ?

Initial pump pressure = 50 psi

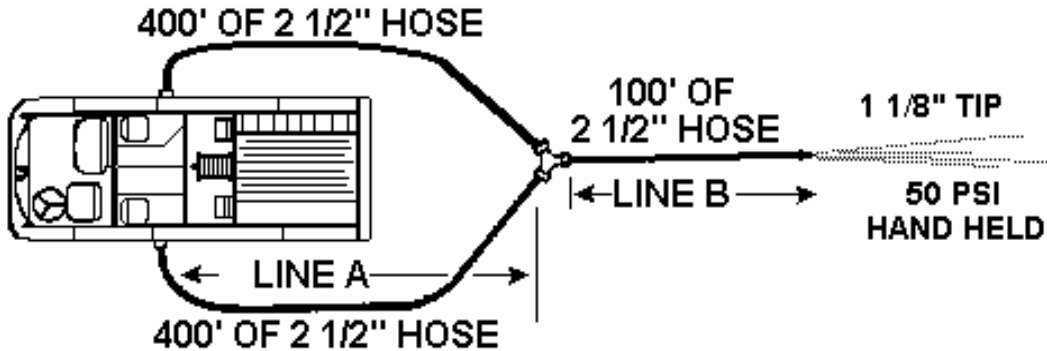

➤ **Step One:** 1 1/8" tip @ 50 psi

$$30 d^2 \sqrt{NP}$$

$$30 \times (1.125)^2 \times 7$$

$$30 \times 1.27 \times 7 = 266.7$$

Round off 266.7 to 270

Flow = **270** gpm

HINT

To convert a fraction to a decimal: divide the numerator by the denominator.

$$1 \div 8 = .125$$

*Flow through one line (a) = $\frac{270}{2}$

Flow (a) = **135** gpm(round off to 140)

Flow through single line (b) = **270** gpm

HINT

When the problem has equal siamese lines, halve the gpm through the two lines and calculate as if it was a single line.

HYDRAULIC SET-UPS AND CALCULATIONS

Siamese Lines (Equal Length)

➤ **Step Two:** $FLR = 2Q^2$

$$FLR = 2 \frac{(gpm)^2}{100}$$

$$FLR = 2 \frac{(140)^2}{100}$$

$$FLR(a) = 2(1.4)^2$$

$$FLR(a) = 2 \times 1.96$$

$$FLR(a) = 3.92 \text{ round off to } 4 \text{ psi}$$

$$FLR = 2 \frac{(gpm)^2}{100}$$

$$FLR = 2 \frac{(270)^2}{100}$$

$$FLR(b) = 2(2.7)^2$$

$$FLR(b) = 2 \times 7.29$$

$$FLR(b) = 14.58 \text{ round off to } 15$$

➤ **Step Three:** $L = \frac{\text{total feet}}{100}$

$$L(a) = \frac{400}{100}$$

$$L(a) = 4$$

$$L(b) = \frac{100}{100}$$

$$L(b) = 1$$

➤ **Step Four:** $TFL = FLR(a) \times L(a) + FLR(b) \times L(b)$

$$FL(a) = 4 \times 4 + FL(b) = 15 \times 1$$

$$FL(a) = 16 + FL(b) = 15$$

$$TFL = 16 + 15 = 31 \text{ psi}$$

$PP = NP + TFL$
 $PP = 50 + 31$
 $PP = 81 \text{ psi}$

HYDRAULIC SET-UPS AND CALCULATIONS

Siamese Lines (Unequal Length)

UNEQUAL SIAMESE LINES, AVERAGE THE LENGTHS AND CALCULATE FLOW.*

Example: 250 gpm SOF nozzle connected to 50' of 2 1/2" hose and two siamese lines:
 One siamese line (a) = 250' of 2 1/2" hose. Second siamese line (b) = 350' of 2 1/2" hose. PP = ?

Initial pump pressure = 100 psi

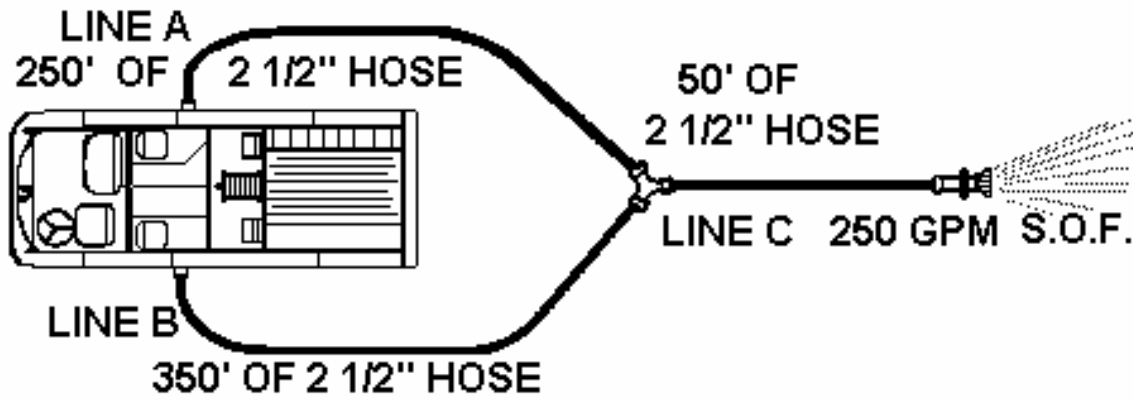

➤ **Step One:** Flow = 250 gpm

$$*Flow\ through\ one\ siamese\ line = \frac{250}{2}$$

$$Flow\ through\ one\ siamese\ line = 125\ gpm$$

$$Round\ off\ Flow\ through\ one\ siamese\ line\ (ab)\ to = 130\ gpm$$

➤ **Step Two:** $FLR = 2Q^2$

$$FLR = 2 \frac{(gpm)^2}{100}$$

$$FLR = 2 \frac{(130)^2}{100} = 1.3$$

$$FLR\ (ab) = 2(1.3)^2$$

$$FLR\ (ab) = 2 \times 1.69 = 3.38$$

Round off 3.38 to 3

$$FLR\ (ab) = 3$$

$$FLR = 2 \frac{(gpm)^2}{100}$$

$$FLR = 2 \frac{(250)^2}{100} = 2.5$$

$$FLR(c) = 2(2.5)^2$$

$$FLR(c) = 2 \times 6.25 = 12.5$$

Round off 12.5 to 13

$$FLR(c) = 13$$

HYDRAULIC SET-UPS AND CALCULATIONS

Siamese Lines (Unequal Length)

- **Step Three:** Determine average lengths of siamesed supply lines

TO DETERMINE L, AVERAGE THE LENGTHS OF SUPPLYING LINES.*

When the average comes out to a ¼ or ¾ length, round off to the nearest ½ or full length respectively.

$$\text{*Average Length of Siamese lines} = \frac{L(a) + L(b)}{2}$$

$$\text{*Average length} = \frac{250 + 350}{2} = 300$$

Siamese lines - Average length (ab) = 300'

Length (c) - Single line = 50

$$L = \frac{\text{total feet}}{100}$$

$$L(ab) = \frac{300}{100}$$

$$L(ab) = 3$$

$$L = \frac{50}{100}$$

$$L(c) = .5$$

- **Step Four:** TFL = FLR(ab) x L(ab) + FLR(c) x L(c)

$$TFL = FL(ab) = 3 \times 3 + FL(c) = 13 \times .5$$

$$TFL = FL(ab) = 9 + FL(c) = 6.5 \text{ (round off to 7)}$$

$$TFL = 9 + 7 = 16$$

$$\begin{aligned} PP &= NP + TFL \\ PP &= 100 + 16 \\ PP &= 116 \text{ psi} \end{aligned}$$

HYDRAULIC SET-UPS AND CALCULATIONS

Wyed Lines (Equal Length and Flow) Straight Tips

Example: Two 1 1/8" tips; two 2 1/2" hose lines, each 100' long, wyed from one 2 1/2" hose line 200' long. PP = ?

Initial pump pressure = 50 psi

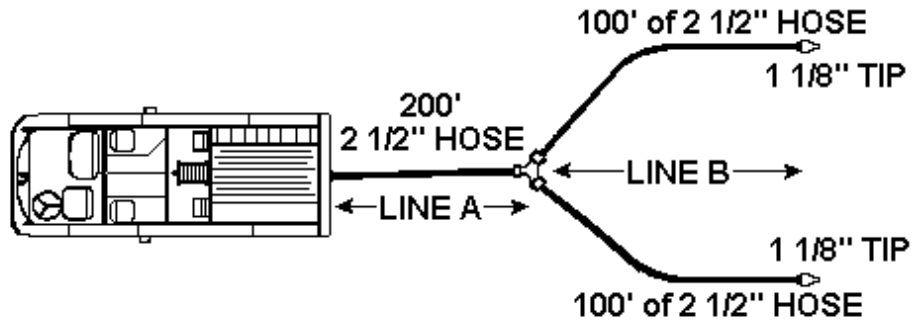

TO DETERMINE THE FLOW IN THE SUPPLY LINE, COMBINE NOZZLE FLOWS.*

Step One: 1 1/8" tip @ 50 psi

$$30 d^2 \sqrt{NP}$$

$$30 \times (1.125)^2 \times 7$$

$$30 \times 1.266 \times 7 = 265.9$$

Round off 265.9 to 270

Flow = 270 gpm through **ONE** line

HINT

To convert a fraction to a decimal: divide the numerator by the denominator.

*Double gpm flow for **SINGLE LINE (A)** = 270 + 270 = 540

*Flow through single line (A) = **540** gpm

Flow in one line of wye (B) = **270** gpm

HYDRAULIC SET-UPS AND CALCULATIONS

Wyed Lines (Equal Length and Flow) Straight Tips

Step Two: $FLR = 2Q^2$

$$FLR = 2 \frac{(gpm)^2}{100}$$

$$FLR = 2 \frac{(gpm)^2}{100}$$

$$FLR (A) = 2 \frac{(540)^2}{100}$$

$$FLR (B) = 2 \frac{(270)^2}{100}$$

$$FLR (A) = 2(5.4)^2$$

$$FLR (B) = 2(2.7)^2$$

$$FLR (A) = 2 \times 29.16$$

$$FLR (B) = 2 \times 7.29$$

$$FLR (A) = 58.32$$

$$FLR (B) = 14.58$$

Round off 58.32 to 58

Round off 14.58 to 15

Single line FLR (A) = **58**

Wyed line FLR (B) = **15**

Step Three: $L = \frac{\text{total feet}}{100}$

$$L (A) = \frac{200}{100}$$

$$L (B) = \frac{100}{100}$$

Single line - L(A) = **2**

Wyed Line - L (B) = **1**

Step Four: $TFL = FLR (A) \times L (A) + FLR (B) \times L (B)$

$$TFL = 58 \times 2 + 15 \times 1$$

$$TFL = 116 + 15 = \mathbf{131 \text{ psi}}$$

HINT

If the lines are the same length and the gpm is the same – calculate for only one line from the wye.

$PP = NP + TFL$ $PP = 50 + 131$ $PP = \mathbf{181 \text{ psi}}$

HYDRAULIC SET-UPS AND CALCULATIONS

Wyed Lines (Unequal Length) Straight Tips

Example: Two 1" tips; Line (C) 400' of 2 1/2" hose, Line (B) 200' of 2 1/2" hose wyed from 150' of 2 1/2" hose Line (A). PP =?

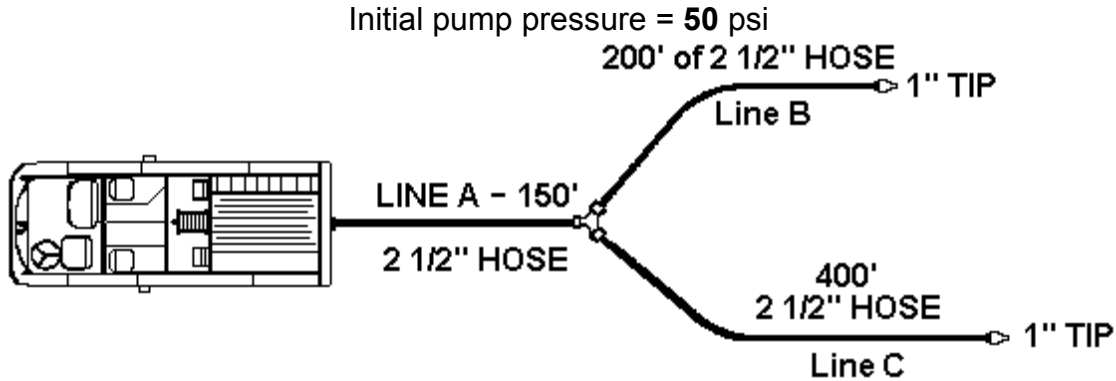

DETERMINE REQUIRED PRESSURES AND PUMP TO THE LONGEST LINE – The lowest pressure nozzle must be gated down at the nozzle. This allows for adequate gpm and nozzle pressure at both nozzles.

Step One: 1" tip @ 50 psi

$$30 d^2 \sqrt{NP}$$

$$30 \times (1)^2 \times 7$$

$$30 \times 1 \times 7 = 210$$

Flow = 210 gpm through **ONE** line

Double gpm flow for **SUPPLY LINE** (A) = 210 + 210

Flow through single line (A) = **420** gpm Flow for one wye line (B or C) = **210** gpm

Step Two: FLR = $2Q^2$

$$FLR = 2 \frac{(gpm)^2}{100}$$

$$FLR = 2 \frac{(gpm)^2}{100}$$

$$FLR (A) = 2 \frac{(420)^2}{100}$$

$$FLR (B or C) = 2 \frac{(210)^2}{100}$$

HYDRAULIC SET-UPS AND CALCULATIONS

Wyed Lines (Unequal Length) Straight Tips

Step Two continued:

$$\text{FLR (A)} = 2(4.2)^2$$

$$\text{FLR (B or C)} = 2(2.1)^2$$

$$\text{FLR (A)} = 2 \times 17.64$$

$$\text{FLR (B or C)} = 2 \times 4.41$$

$$\text{FLR (A)} = 35.28$$

$$\text{FLR (B or C)} = 8.82$$

Round off 35.28 to 35

Round off 8.82 to 9

FLR in line (A) = **35**

FLR in one wyed line (B or C) = **9**

Step Three: $L = \frac{\text{total feet}}{100}$

DETERMINE L FOR THE LONGEST LINE

$$L (A) = \frac{150}{100}$$

$$L (C) = \frac{400}{100}$$

$$L (A) = 1.5$$

$$L (C) = 4$$

Step Four: $\text{TFL} = \text{FLR (A)} \times L (A) + \text{FLR (B or C)} \times L(C)$

$$\text{TFL} = 35 \times 1.5 + 9 \times 4$$

FLR (A) Round off 52.5 to 53

$$\text{TFL} = 53 + 36 = \mathbf{89} \text{ psi}$$

HINT

When gpm's are equal, only calculate FLR for the longest wyed line.

$\text{PP} = \text{NP} + \text{TFL}$ $\text{PP} = 50 + 89$ $\text{PP} = \mathbf{139 \text{ psi}}$

HYDRAULIC SET-UPS AND CALCULATIONS

Wyed Lines (Unequal Flows) Straight Tips

Example: 2 tips, Line B is a 1" tip on 200' of 2 1/2" hose; Line C is a 7/8" tip on 200' of 2 1/2" hose, wyed from Line A 200' of 2 1/2" hose. PP =?

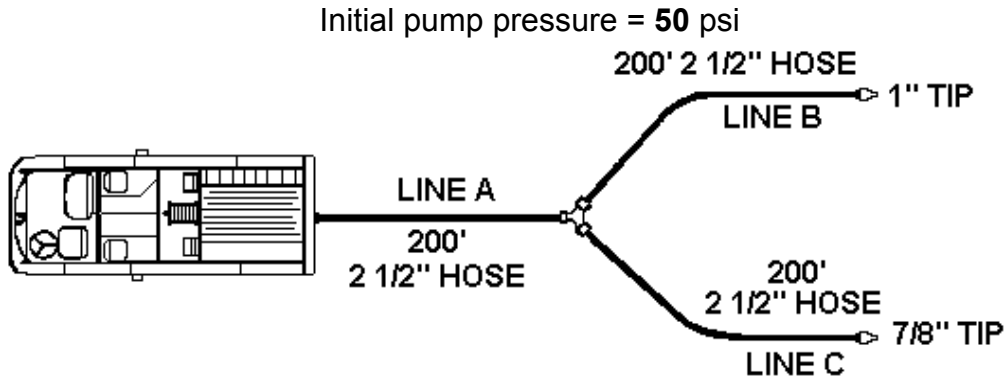

DETERMINE REQUIRED PRESSURES AND PUMP TO THE HIGHEST GPM LINE – The lower gpm line must be gated down at the nozzle. This allows for adequate gpm and nozzle pressure for both lines.

Step One: 1" tip @ 50 psi

$$30 d^2 \sqrt{NP}$$

$$30 \times (1)^2 \times 7$$

$$30 \times 1 \times 7 = 210$$

$$1" \text{ tip Flow (B)} = \mathbf{210}$$

7/8" tip @ 50 psi

$$30 d^2 \sqrt{NP}$$

$$30 \times (.875)^2 \times 7$$

$$30 \times .765 \times 7 = 160.65$$

Round off 160.65 to 160

$$7/8" \text{ tip Flow (C)} = \mathbf{160}$$

HINT

To convert a fraction to a decimal: divide the numerator by the denominator.

$$\text{Total Flow} = 210 + 160 = \mathbf{370}$$

$$\text{Flow through supply line (A)} = \mathbf{370} \text{ gpm}$$

$$\text{Highest Flow is } 1" \text{ tip line (B)} = \mathbf{210} \text{ gpm}$$

HYDRAULIC SET-UPS AND CALCULATIONS

Wyed Lines (Unequal Flows)

Step Two: $FLR = 2Q^2$

$$FLR = 2 \frac{(gpm)^2}{100}$$

$$FLR (A) = 2 \frac{(370)^2}{100}$$

$$FLR (A) = 2(3.7)^2$$

$$FLR(A) = 2 \times 13.69 = 27.38$$

Round off 27.38 to 27

FLR for supply line (A) = **27**

Highest gpm flow Line (B)

$$FLR = 2 \frac{(gpm)^2}{100}$$

$$FLR (B) = 2 \frac{(210)^2}{100}$$

$$FLR (B) = 2(2.1)^2$$

$$FLR (B) = 2 \times 4.41 = 8.82$$

Round off 8.82 to 9

FLR for line (B) = **9**

Step Three: L = total feet

DETERMINE L FOR THE HIGHEST GPM WYED LINE

$$L (A) = \frac{200}{100}$$

$$L (B) = \frac{200}{100}$$

$$L (A) = 2$$

$$L (B) = 2$$

Step Four: $TFL = FLR (A) \times L (A) + FLR (B) \times L (B)$

$$TFL = 27 \times 2 + 9 \times 2$$

$$TFL = 54 + 18 = \mathbf{72 \text{ psi}}$$

$$PP = NP + TFL$$

$$PP = 50 + 72$$

$$PP = \mathbf{122 \text{ psi}}$$

HYDRAULIC SET-UPS AND CALCULATIONS

Wyed Lines (Equal Lines and Flow) Fog Nozzles

Example: Two 100' - 2 1/2" hose lines with 250 gpm SOF nozzles, wyed from 200' of 2 1/2" hose.
 PP = ?

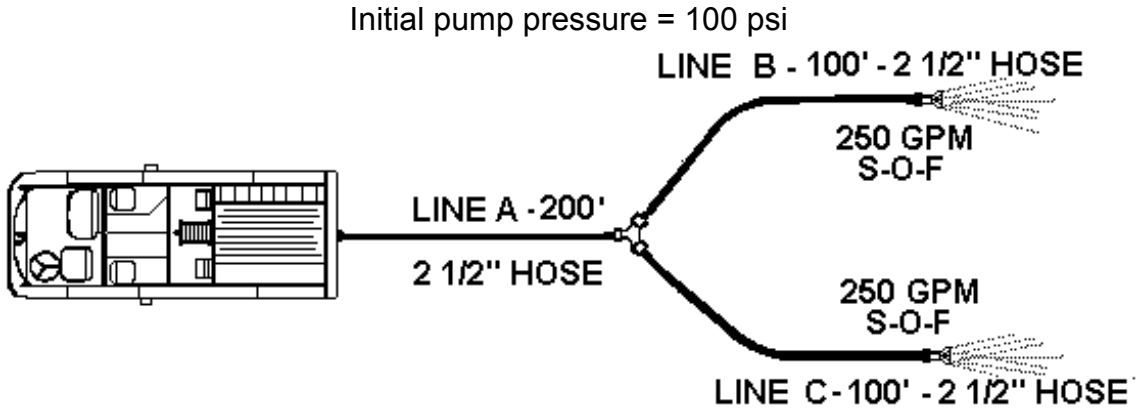

TO DETERMINE THE FLOW IN THE SUPPLY LINE, COMBINE NOZZLE FLOWS.*

Step One: Flow through one line = **250 gpm**

*Flow through supply line (A) = 250 + 250 = 500 gpm

*Flow through supply line (A) = **500 gpm**

Step Two: $FLR = 2Q^2$

$$FLR = 2 \frac{(gpm)^2}{100}$$

$$FLR = 2 \frac{(gpm)^2}{100}$$

$$FLR = 2 \frac{(500)^2}{100}$$

$$FLR = 2 \frac{(250)^2}{100}$$

$$FLR (A) = 2(5)^2$$

$$FLR (B \text{ or } C) = 2(2.5)^2$$

$$FLR (A) = 2 \times 25 = 50$$

$$FLR (B \text{ or } C) = 2 \times 6.25 = 12.5$$

Round off 12.5 to 13

$$FLR \text{ for supply line (A)} = \mathbf{50}$$

$$FLR \text{ for one wye line (B or C)} = \mathbf{13}$$

HYDRAULIC SET-UPS AND CALCULATIONS

Wyed Lines (Equal Lines and Flow) Fog Nozzles

Step Three: $L = \frac{\text{total feet}}{100}$

$$L (A) = \frac{200}{100}$$

$$L (A) = 2$$

$$L (B \text{ or } C) = \frac{100}{100}$$

$$L (B \text{ or } C) = 1$$

HINT

If the lines are the same length and the gpm is the same – calculate FLR for only one line from the wye.

Step Four: $TFL = FLR (A) \times L (A) + FLR (B) \times L (B)$

$$TFL = 50 \times 2 + 13 \times 1$$

$$TFL = 100 + 13 = \mathbf{113}$$

$PP = NP + TFL$ $PP = 100 + 113$ $\underline{PP = 213 \text{ psi}}$

HYDRAULIC SET-UPS AND CALCULATIONS

Wyed Lines (2 1/2" to 1 3/4")

Determining flow from 2 1/2" supply line with two 1 3/4" wyed lines.

Example: Two 1 1/2" Akron nozzles, 125 gpm setting, two 200' lines of 1 3/4" hose wyed from 400' of 2 1/2" hose. PP = ?

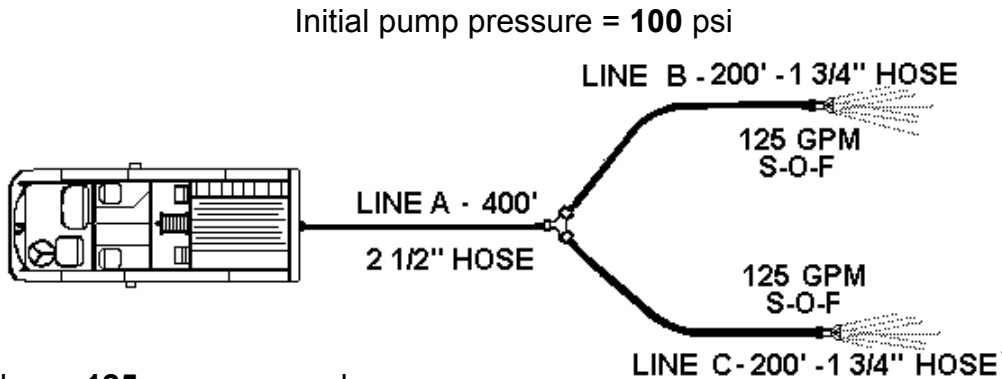

Step One: Flow = 125 gpm per nozzle

EF = Factor x gpm

EF flow through 1 3/4" hose = 2.0 x 125

EF flow through 1 3/4" hose = **250 gpm**

Flow through 2 1/2" hose = 125 + 125

Flow through 2 1/2" hose = **250 gpm**

Step Two: FLR = $2Q^2$

$$FLR = 2 \frac{(gpm)^2}{100}$$

$$FLR = 2 \frac{(250)^2}{100}$$

$$FLR(A) = 2(2.5)^2$$

$$FLR(A) = 2 \times 6.25 = 12.5$$

Round off 12.5 to 13

FLR for 2 1/2" supply line = **13**

HINT

For 2 1/2" flows
between **180 & 320**,
subtract **12** from the
first 2 numbers.

$$\text{(250 - 12 = 13)}$$

FLR for 1 3/4" line = **13**

HYDRAULIC SET-UPS AND CALCULATIONS

Wyed Lines (2 ½ to 1 ¾)

Step Three: $L = \frac{\text{total feet}}{100}$

$$L (A) = \frac{400}{100}$$

$$L (A) = 4$$

$$L (B \text{ or } C) = \frac{200}{100}$$

$$L (B \text{ or } C) = 2$$

HINT

If the lines are the same length and the gpm is the same – calculate FLR for only one line of the wye.

Step Four: $TFL = FLR (A) \times L (A) + FLR (B \text{ or } C) \times L (B \text{ or } C)$

$$TFL = 13 \times 4 + 13 \times 2$$

$$TFL = 52 + 26 = 78 \text{ psi}$$

$$\begin{aligned} PP &= NP + TFL \\ PP &= 100 + 78 \\ \underline{PP} &= \underline{178 \text{ psi}} \end{aligned}$$

HYDRAULIC SET-UPS AND CALCULATIONS

Appliances (Heavy Stream) - Deluge set

Example: 2" tip on monitor nozzle supplied by three 200' x 2 1/2" hose lines. PP =?

Initial pump pressure = 80 psi

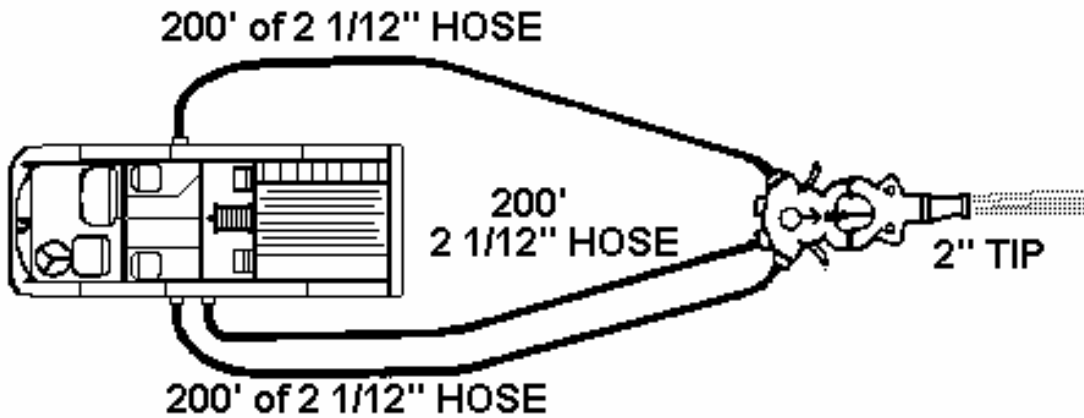

ALLOW 15 PSI APPLIANCE LOSS WHEN USING A DELUGE SET OR MONITOR NOZZLE*

NOTE: To be considered an appliance it must meet three things:

1. Made of metal (other than hose)
2. Water flows through it
3. A change of direction greater than 90°

➤ **Step One:** 2" tip @ 80 psi

$$30 d^2 \sqrt{NP}$$

$$30 \times (2)^2 \times 9$$

$$30 \times 4 \times 9 = 1080$$

Round off 1080 to 1100

Flow = **1100**

$$\text{Flow through one line} = \frac{1100}{3}$$

$$\text{Flow through one line} = 367$$

Round off 367 to **370** gpm

HINT

Average flow and calculate as a single line.

HYDRAULIC SET-UPS AND CALCULATIONS

Appliances (Heavy Stream) - Deluge set

- **Step Two:** $FLR = 2Q^2$
- $$FLR = 2 \frac{(gpm)^2}{100}$$
- $$FLR = 2 \frac{(370)^2}{100} = 3.7$$
- $$FLR = 2(3.7)^2$$
- $$FLR = 2 \times 13.69 = 27.38$$
- Round off 27.38 to 27
- $$FLR = \mathbf{27 \text{ psi}}$$

- **Step Three:** $L = \frac{\text{total feet}}{100}$
- $$L = \frac{200}{100}$$
- $$L = \mathbf{2}$$

- **Step Four:** $TFL = FLR \times L$
- $$TFL = 27 \times 2$$
- $$TFL = \mathbf{54 \text{ psi}}$$

$PP = NP + TFL + AL^*$ $PP = 80 + 54 + 15$ $PP = \mathbf{149 \text{ psi}}$
--

HYDRAULIC SET-UPS AND CALCULATIONS

Appliances (Heavy Stream) - Deluge set

Example: 1000 gpm Fog Nozzle supplied by three 100' x 2 1/2" hose lines. PP =?

Initial pump pressure = 100 psi

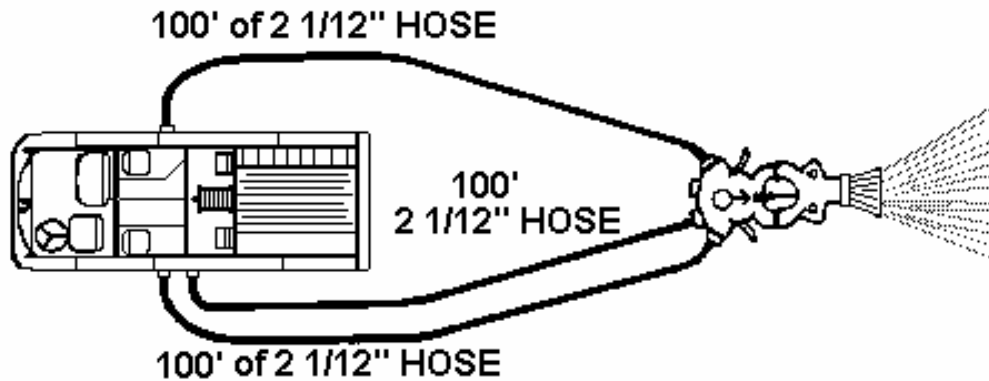

ALLOW 15 PSI APPLIANCE LOSS WHEN USING A DELUGE SET OR MONITOR NOZZLE*

➤ **Step One:** Flow = 1000 gpm

$$\text{Flow through one line} = \frac{1000}{3}$$

$$\text{Flow through one line} = 333$$

Round off single line flow to 330 gpm

$$\text{Flow} = \mathbf{330}$$

HINT

Average flow and calculate as a single line.

➤ **Step Two:** $FLR = 2Q^2$

$$FLR = 2 \frac{(\text{gpm})^2}{100}$$

$$FLR = 2 \frac{(\mathbf{330})^2}{100} = 3.3$$

$$FLR = 2(3.3)^2$$

$$FLR = 2 \times 10.89 = 21.78$$

Round off 21.78 to 22

$$FLR = \mathbf{22} \text{ psi}$$

HYDRAULIC SET-UPS AND CALCULATIONS

Appliances (Heavy Stream) - Deluge set

➤ **Step Three:** $L = \frac{\text{total feet}}{100}$

$$L = \frac{100}{100}$$

$$L = 1$$

➤ **Step Four:** $TFL = FLR \times L$

$$TFL = 22 \times 1$$

$$TFL = \mathbf{22 \text{ psi}}$$

$\begin{aligned} PP &= NP + TFL + AL^* \\ PP &= 100 + 22 + 15 \\ PP &= \mathbf{137 \text{ psi}} \end{aligned}$
--

HYDRAULIC SET-UPS AND CALCULATIONS

Appliances (Heavy Stream) – Apparatus Deck Gun

Example: 2” tip from apparatus mounted deck gun, PP =?

Initial pump pressure = 80

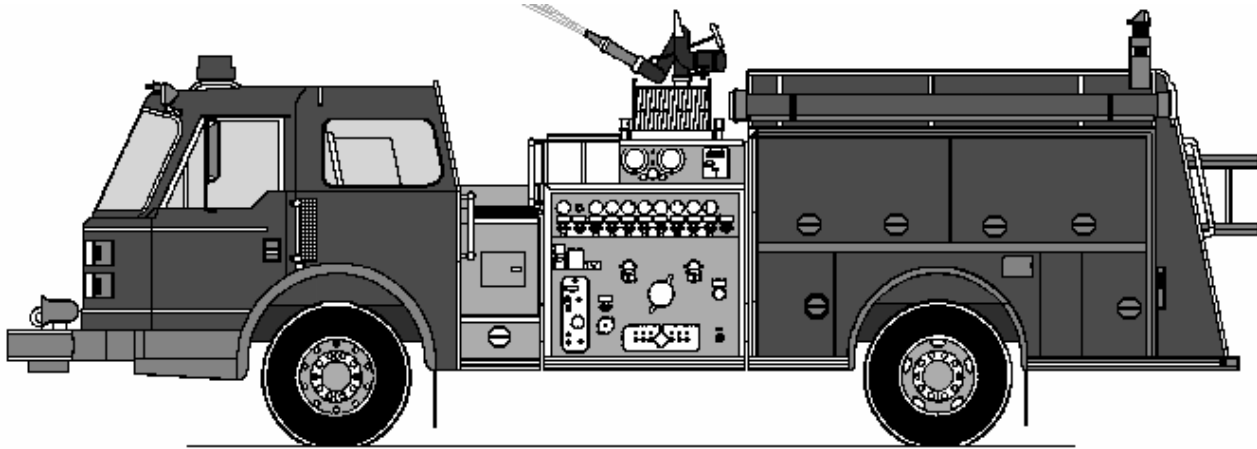

ALLOW 15 PSI APPLIANCE LOSS WHEN USING A DELUGE SET OR MONITOR NOZZLE

➤ **Step One:** Flow = 1100 gpm

➤ **Nozzle Pressure = 80**

➤ ***Appliance Loss = 15**

HINT

DISCHARGE IS DIRECTLY OFF THE PUMP.
NO HOSE FRICTION LOSS CALCULATIONS
NEED TO BE MADE.

$$\begin{aligned}
 PP &= NP + AL^* \\
 PP &= 80 + 15 \\
 PP &= \underline{95 \text{ psi}}
 \end{aligned}$$

HYDRAULIC SET-UPS AND CALCULATIONS

TRUCKS



Ladder truck configuration and hydraulics vary greatly between manufactures.

Because of this the calculations also vary. When flow meters and nozzle pressure gauges are installed, the use of these meters and gauges will be the final guide for correct pressure and flow.

HYDRAULIC SET-UPS AND CALCULATIONS

Appliances (Heavy Stream) Ladder Pipes

Example: 1 3/4" tip, ladder pipe elevation, 70' up, 200' of 4" hose line. PP = ?

Initial pump pressure = **150** psi.

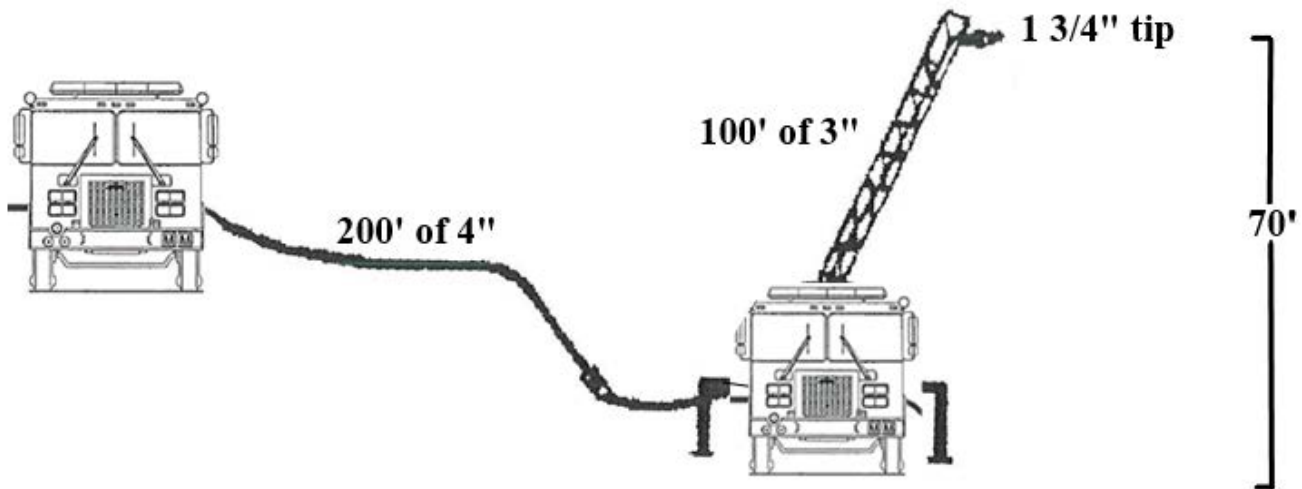

➤ **Step One:** 1 3/4" tip @ 80 psi

$$30 d^2 \sqrt{NP}$$

$$30 \times (1.75)^2 \times 9$$

$$30 \times 3.06 \times 9 = 826.2$$

Round off 826.2 to 800

Flow = **800** gpm

EF(a) through 4" hose = .25 x 800

EF(a) through 4" hose = **200** gpm

EF(b) through 3" hose = .67 x 800

EF(b) through 3" hose = 540 gpm

HINT

To convert a fraction to a decimal: divide the numerator by the denominator.

$$3 \div 4 = .75$$

HINT

It's easier to divide by 4 than multiply by .25

HYDRAULIC SET-UPS AND CALCULATIONS

Appliances (Heavy Stream) Ladder Pipes

➤ **Step Two:** $FLR = 2Q^2$

$$FLR = 2 \frac{(gpm)^2}{100}$$

$$FLR = 2 \frac{(200)^2}{100} = 8$$

$$FLR(a) = 2(2)^2$$

$$FLR(a) = 2 \times 4 = 8$$

$$FLR (4'') = 8$$

$$FLR = 2 \frac{(gpm)^2}{100}$$

$$FLR = 2 \frac{(540)^2}{100} = 5.4$$

$$FLR(b) = 2(5.4)^2$$

$$FLR(b) = 2 \times 29.16 = 58.32$$

Round 58.32 to 58

$$FLR (3'') = 58$$

➤ **Step Three:** $L = \frac{\text{total feet}}{100}$

$$L(a) = \frac{200}{100}$$

$$L(a) (4'') = 2$$

$$L(b) = \frac{100}{100}$$

$$L(b) (3'') = 1$$

➤ **Step Four:** $TFL = FLR (4'') \times L + FLR (3'') \times L$

$$TFL = 8 \times 2 + 58 \times 1$$

$$TFL = 16 + 58 = 74 \text{ psi}$$

➤ **Step Five:** $GL = .5 \times H$

$$GL = .5 \times 70$$

$$GL = 35$$

$$PP = NP + TFL + AL + GL$$

$$PP = 80 + 74 + 15 + 35$$

$$PP = \underline{204 \text{ psi}}$$

HYDRAULIC SET-UPS AND CALCULATIONS

Appliances (Heavy Stream) Aerial Platform Operations

Example: Aerial Platform up 50 feet with 1000 gpm fog nozzle supplied by three 100' lengths of 2 1/2" hose. PP =?

Initial pump pressure = **150** psi.

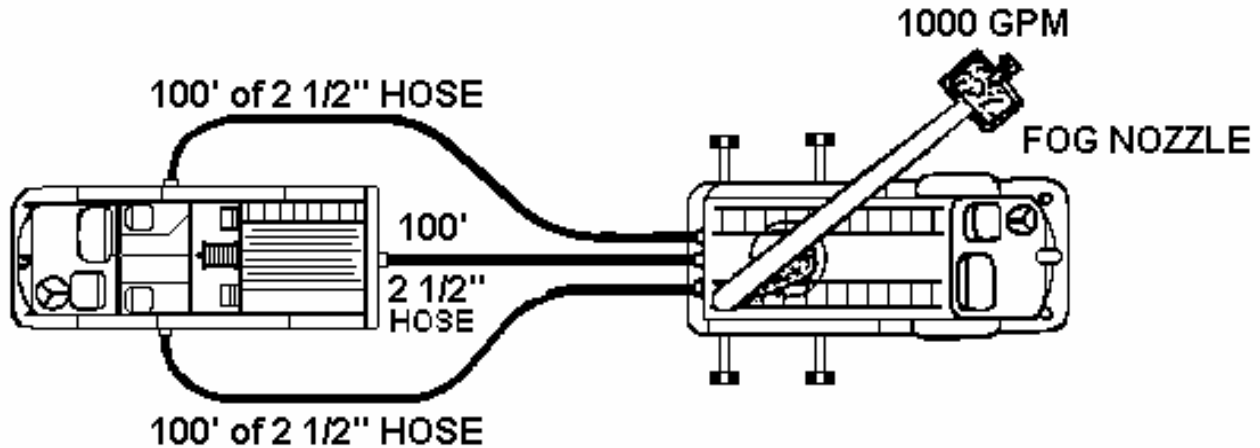

- **Step One:** Flow = 1000 gpm
 Flow through one line = $\frac{1000}{3}$
 Flow through one line = 333
 Round off single line flow to 330
 Flow = **330** gpm

HINT

Average flow and calculate as a single line.

- **Step Two:** $FLR = 2Q^2$
 $FLR = 2 \frac{(gpm)^2}{100}$
 $FLR = 2 \frac{(330)^2}{100} = 3.3$
 $FLR = 2(3.3)^2$
 $FLR = 2 \times 10.89 = 21.78$
 Round off 21.78 to 22

$$\text{FLR} = 22 \text{ psi}$$

HYDRAULIC SET-UPS AND CALCULATIONS

Appliances (Heavy Stream) Aerial Platform Operations

➤ **Step Three:** $L = \frac{\text{total feet}}{100}$

$$L = \frac{100}{100}$$

$$L = 1$$

➤ **Step Four:** $\text{TFL} = \text{FLR} \times L$

$$\text{TFL} = 22 \times 1$$

$$\text{TFL} = \mathbf{22 \text{ psi}}$$

➤ **Step Five:** $\text{GL} = .5 \times H$

$$\text{GL} = .5 \times 50$$

$$\text{GL} = \mathbf{25}$$

$$\mathbf{PP = NP + TFL + LSL + GL}$$

$$\mathbf{PP = 100 + 22 + 25 + 25}$$

$$\mathbf{\underline{PP = 172 \text{ psi}}}$$

HYDRAULIC SET-UPS AND CALCULATIONS

Appliances (Heavy Stream) Pre-plumbed Service Aerial

Example: Pre-plumbed ladder pipe, up 100 feet with 1000 gpm fog nozzle supplied by three 100' lengths of 2 1/2" hose. PP =?

Initial pump pressure = **150** psi.

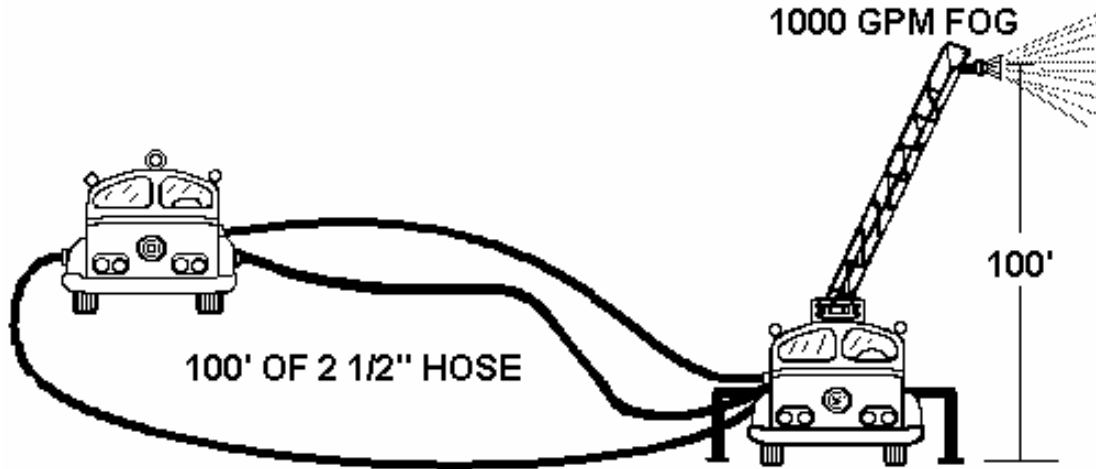

- **Step One:** Flow = 1000 gpm
 Flow through one line = $\frac{1000}{3}$
 Flow through one line = 333
 Round off single line flow to 330
 Flow = **330** gpm

HINT

Average flow and calculate as a single line.

- **Step Two:** $FLR = 2Q^2$
 $FLR = 2 \frac{(gpm)^2}{100}$
 $FLR = 2 \frac{(330)^2}{100} = 3.3$
 $FLR = 2(3.3)^2$
 $FLR = 2 \times 10.89 = 21.78$
 Round off 21.78 to 22

$$\text{FLR} = 22 \text{ psi}$$

HYDRAULIC SET-UPS AND CALCULATIONS

Appliances (Heavy Stream) Pre-plumbed Service Aerial

➤ **Step Three:** $L = \frac{\text{total feet}}{100}$

$$L = \frac{100}{100}$$

$$L = 1$$

➤ **Step Four:** $\text{TFL} = \text{FLR} \times L$

$$\text{TFL} = 22 \times 1$$

$$\text{TFL} = 22 \text{ psi}$$

➤ **Step Five:** $\text{GL} = .5 \times H$

$$\text{GL} = .5 \times 100$$

$$\text{GL} = 50$$

$$\text{PP} = \text{NP} + \text{TFL} + \text{LSL} + \text{GL}$$

$$\text{PP} = 100 + 22 + 25 + 50$$

$$\text{PP} = \underline{197 \text{ psi}}$$

HYDRAULIC SET-UPS AND CALCULATIONS

Appliances (Heavy Stream) Aerial Platform Operations 4" Hose

Example: Aerial Platform up 70 feet with 1000 gpm fog nozzle supplied by 200' of 4" hose.

PP = ?

Initial pump pressure = **150** psi.

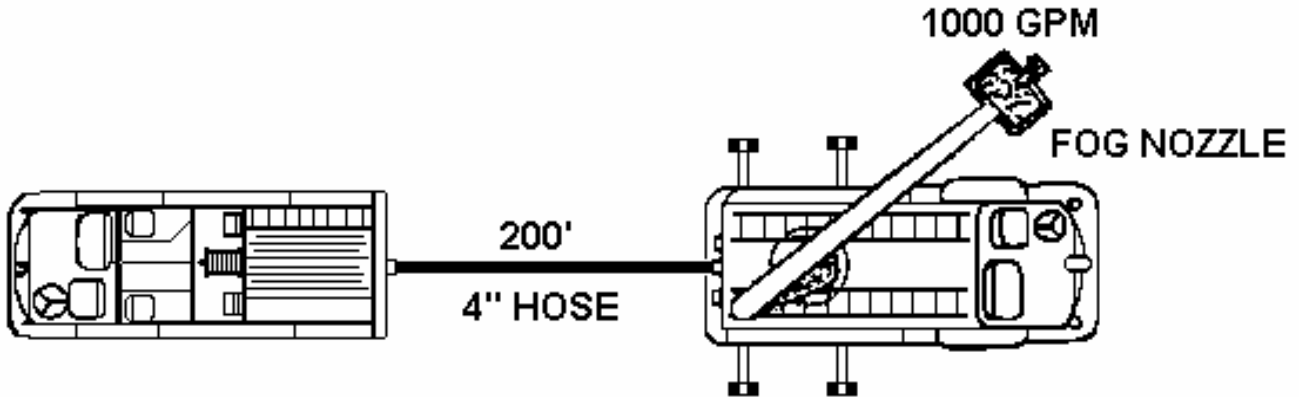

- **Step One:** Flow = **1000** gpm
 EF = 1000 x .25
 EF = **250** gpm

- **Step Two:** FLR = $2Q^2$
 $FLR = 2 \frac{(gpm)^2}{100}$
 $FLR = 2 \frac{(250)^2}{100} = 2.5$
 $FLR = 2(2.5)^2$
 $FLR = 2 \times 6.25 = 12.5$
 Round off 12.5 to 13
 FLR = **13** psi

HINT

For 2 ½" flows
 between **180 & 320**
 subtract **12** from the
 first 2 numbers.
(250 - 12 = 13)

See friction loss
 table in appendix

HYDRAULIC SET-UPS AND CALCULATIONS

Appliances (Heavy Stream) Aerial Platform Operations 4" Hose

➤ **Step Three:** $L = \frac{\text{total feet}}{100}$

$$L = \frac{200}{100}$$

$$L = 2$$

➤ **Step Four:** $TFL = FLR \times L$

$$TFL = 13 \times 2$$

$$TFL = 26 \text{ psi}$$

➤ **Step Five:** $GL = .5 \times H$

$$GL = .5 \times 70$$

$$GL = 35$$

$$PP = NP + TFL + LSL + GL$$

$$PP = 100 + 26 + 25 + 35$$

$$\underline{PP = 186 \text{ psi}}$$

HYDRAULIC SET-UPS AND CALCULATIONS

Appliances (Heavy Stream) Pre-plumbed Service Aerial

Example: Pre-plumbed ladder pipe, up 100 feet with 1000 gpm fog nozzle supplied by 400' of 4" hose. PP = ?

Initial pump pressure = **150** psi.

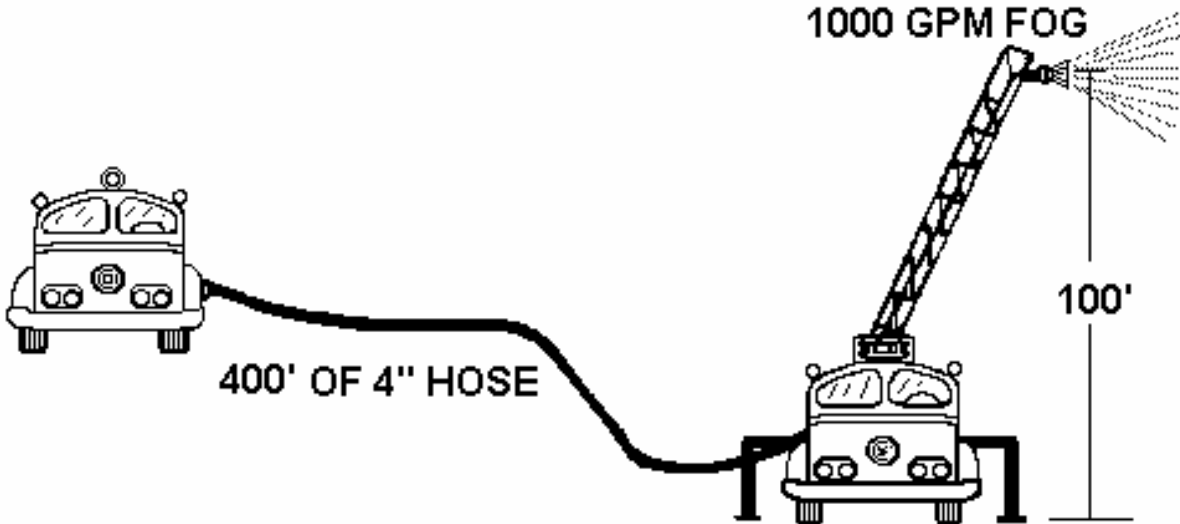

➤ **Step One:** Flow = **1000** gpm

$$EF = 1000 \times .25$$

$$EF = \mathbf{250} \text{ gpm}$$

➤ **Step Two:** $FLR = 2Q^2$

$$FLR = 2 \frac{(\text{gpm})^2}{100}$$

$$FLR = 2 \frac{(\mathbf{250})^2}{100} = 2.5$$

$$FLR = 2(2.5)^2$$

$$FLR = 2 \times 6.25 = 12.5$$

Round off 12.5 to 13

$$FLR = \mathbf{13} \text{ psi}$$

HINT

For 2 ½" flows between **180 & 320** subtract **12** from the first 2 numbers.

$$(\mathbf{250} - \mathbf{12} = \mathbf{13})$$

See friction loss table in appendix

HYDRAULIC SET-UPS AND CALCULATIONS

Appliances (Heavy Stream) Pre-plumbed Service Aerial

➤ **Step Three:** $L = \frac{\text{total feet}}{100}$

$$L = \frac{400}{100}$$

$$L = 4$$

➤ **Step Four:** $TFL = FLR \times L$

$$TFL = 13 \times 4$$

$$TFL = \mathbf{52 \text{ psi}}$$

➤ **Step Five:** $GL = .5 \times H$

$$GL = .5 \times 100$$

$$GL = \mathbf{50}$$

$$\mathbf{PP = NP + TFL + LSL + GL}$$

$$\mathbf{PP = 100 + 52 + 25 + 50}$$

$$\mathbf{PP = \underline{227 \text{ psi}}}$$

HYDRAULIC SET-UPS AND CALCULATIONS

Standpipes – Red Hose and High-rise pack

Example: Two 200' lines of 2 1/2" hose are laid from the pump to the standpipe intake.

Two 100' 1 3/4" Fire fighting lines, each flowing 200 gpm on the 15 floor. One is connected to the standpipe on the 15 floor, the other is connected on the 14th floor. PP = ?

Initial pump pressure = Maintain **150** psi at the pump until proper pump pressure can be determined.

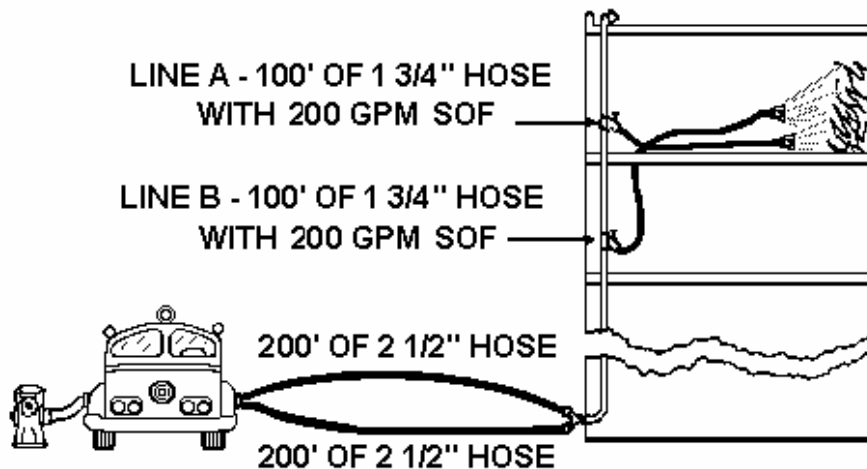

ALLOW **25** PSI LOSS FOR STANDPIPE SYSTEMS (**SL**) REGARDLESS OF SIZE. *

ALLOW **5** PSI GRAVITY LOSS (**GL**) PER FLOOR, ABOVE THE GROUND FLOOR, INCLUDING THE FLOOR THE NOZZLE IS ON. (**DO NOT COUNT THE FIRST FLOOR.** **)

Step One: 200 gpm flow for each 1 3/4"

Total Flow through stand pipe = **400** gpm nozzle

1 3/4" **EF** through 2 1/2" = 2 x 200 = 400

EF = 400

Total flow = 400 gpm

Flow through single supply line = $\frac{400}{2} = 200$ gpm
(number of lines)

HINT

This lay is a version of the Siamese lay. Divide flow by number of supply lines and treat as a single line.

HYDRAULIC SET-UPS AND CALCULATIONS

Standpipes – Red Hose and High-rise pack

2 1/2"

1 3/4"

➤ **Step Two:** FLR = $2Q^2$

$$FLR = 2 \frac{(gpm)^2}{100}$$

$$FLR = 2 \frac{(gpm)^2}{100}$$

$$FLR = 2 \frac{(200)^2}{100} = 8$$

$$FLR = 2 \frac{(400)^2}{100} = 32$$

$$FLR(2 \frac{1}{2}") = 2(2)^2$$

$$FLR(1 \frac{3}{4}") = 2(4)^2$$

$$FLR (2 \frac{1}{2}") = 2 \times 4 = 8$$

$$FLR(1 \frac{3}{4}") = 2 \times 16 = 32$$

$$FLR (2 \frac{1}{2}") = 8$$

$$FLR(1 \frac{3}{4}") = 32$$

➤ **Step Three:** L = $\frac{\text{total feet}}{100}$

$$L = \frac{200}{100}$$

$$L = \frac{100}{100}$$

$$L(2 \frac{1}{2}") = 2$$

$$L(1 \frac{3}{4}") = 1$$

➤ **Step Four:** TFL = FLR (2 1/2") x L(2 1/2") + FLR (1 3/4") x L(1 3/4")

$$TFL (2 \frac{1}{2}") = 8 \times 2 + 32 \times 1$$

$$TFL (2 \frac{1}{2}") = 16 + 32 \text{ psi}$$

$$TFL = 48$$

➤ **Step Five:** **GL = 5 x 14

$$GL = 70 \text{ psi}$$

HINT

DON'T INCLUDE THE FIRST FLOOR WHEN CALCULATING GL FOR STANDPIPES

$$PP = NP + TFL + SL^* + GL^{**}$$

$$PP = 100 + 48 + 25 + 70$$

$$PP = 243 \text{ psi}$$

HYDRAULIC SET-UPS AND CALCULATIONS

Standpipes – Aerial Ladder as Mobile Standpipe

Example: An aerial ladder is supplied by 400' of 4" hose line. The aerial ladder is to a sixth floor window with two 150' 1 3/4" fire fighting lines flowing from a wye at the end of the ladder. Each SOF nozzle is flowing 150 gpm. PP =?

Initial pump pressure = Maintain **150** psi at the pump until proper pump pressure can be determined.

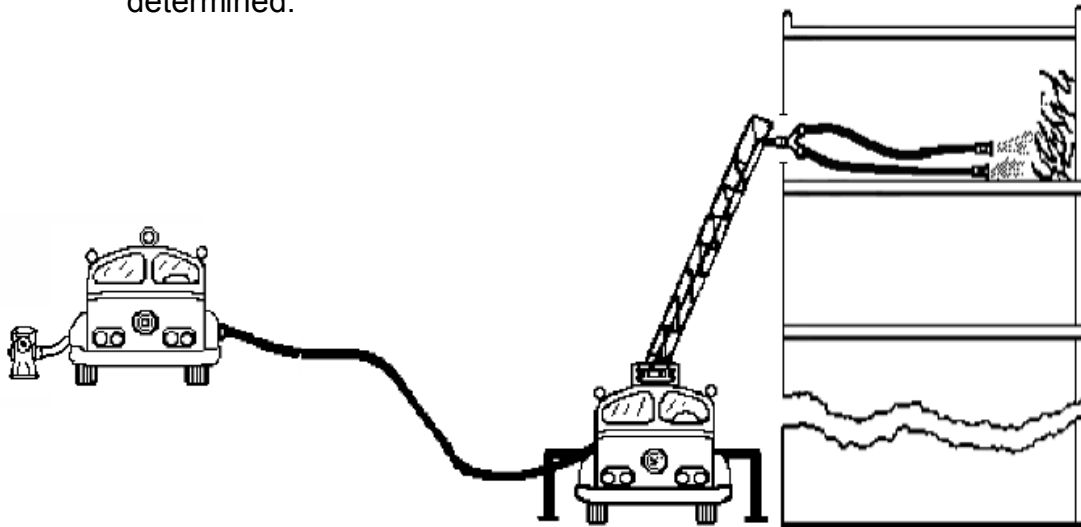

ALLOW **25** PSI LOSS FOR LADDER SYSTEM LOSS (LSL).*

ALLOW **5** PSI GRAVITY LOSS (GL) PER FLOOR, ABOVE THE GROUND FLOOR, INCLUDING THE FLOOR THE NOZZLE IS ON. (DO NOT COUNT THE FIRST FLOOR. **)

Step One: 150 gpm flow for each 1 3/4"

Total Flow through aerial ladder and 4" hose = **300** gpm

1 3/4" EF through 2 1/2" = 2 x 150 = 300

1 3/4" EF = **300**

Total flow through 4" supply line = **300** gpm

4" EF = .25 x 300 = **75**

HINT

This lay is calculated the same as the Standpipe lay.

HYDRAULIC SET-UPS AND CALCULATIONS

Standpipes – Aerial Ladder as Mobile Standpipe

4"

1 3/4"

Step Two: $FLR = 2Q^2$

$$FLR = 2 \frac{(gpm)^2}{100}$$

$$FLR = 2 \frac{(gpm)^2}{100}$$

$$FLR = 2 \frac{(75)^2}{100}$$

$$FLR = 2 \frac{(300)^2}{100}$$

$$FLR (4") = 2(.75)^2$$

$$FLR (1 \frac{3}{4} ") = 2(3)^2$$

$$FLR (4") = 2 \times .5625 = 8$$

$$FLR (1 \frac{3}{4} ") = 2 \times 9 = 18$$

$$FLR (4") = 1.125 \text{ round off to } 1$$

$$FLR (1 \frac{3}{4} ") = 18$$

Step Three: $L = \frac{\text{total feet}}{100}$

$$L = \frac{400}{100}$$

$$L = \frac{150}{100}$$

$$L (4") = 4$$

$$L (1 \frac{3}{4} ") = 1.5$$

Step Four: $TFL = FLR (4") \times L (4") + FLR (1 \frac{3}{4} ") \times L (1 \frac{3}{4} ")$

$$TFL (2 \frac{1}{2} ") = 1 \times 4 + 18 \times 1.5$$

$$TFL (2 \frac{1}{2} ") = 4 + 27$$

$$TFL = 31 \text{ psi}$$

Step Five: $**GL = 5 \times 5$

$$GL = 25 \text{ psi}$$

$$PP = NP + TFL + LSL^* + GL^{**}$$

$$PP = 100 + 31 + 25 + 25$$

$$PP = 181 \text{ psi}$$

HINT

DO NOT INCLUDE
THE FIRST FLOOR
WHEN
CALCULATING GL
FOR STANDPIPES.

HYDRAULIC SET-UPS AND CALCULATIONS

Standpipes – Blue Hose and High-rise Pack

Example: Two 200' lines of 2 ½" hose are laid from the pump to the standpipe intake.

Two 200' 1 ¾" Fire fighting lines, each flowing 200 gpm on the 31st floor. One is connected to the standpipe on the 31st floor, the other is connected on the 30th floor. PP = ?

Initial pump pressure = Maintain **150** psi at the pump until proper pump pressure can be determined.

BLUE HIGH PRESSURE HOSE HAS A SERVICE PRESSURE OF 600 POUNDS.

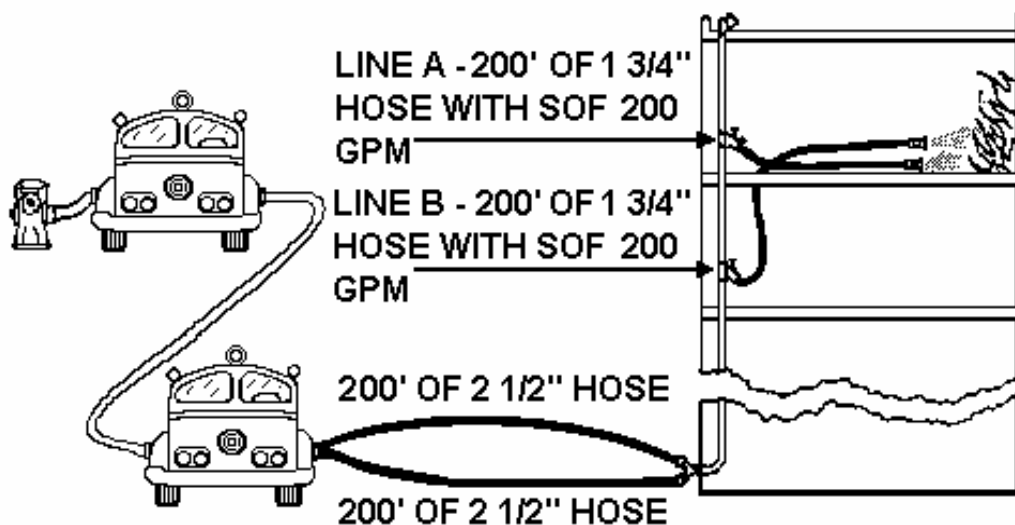

ALLOW 25 PSI LOSS FOR STANDPIPE SYSTEMS (SL) REGARDLESS OF SIZE. *

ALLOW 5 PSI GRAVITY LOSS (GL) PER FLOOR, ABOVE THE GROUND FLOOR, INCLUDING THE FLOOR THE NOZZLE IS ON. (DO NOT COUNT THE FIRST FLOOR. **)

- **Step One:** 200 gpm through each nozzle
 - EF through 1 ¾" 200 x 2 = **400**
 - Total Flow through stand pipe = **400** gpm
 - Flow through single supply line = **200** gpm

HINT

This lay is a version of the Siamese lay. Divide flow by number of supply lines and treat as a single line.

HYDRAULIC SET-UPS AND CALCULATIONS

Standpipes – Blue Hose and High-rise Pack

2 ½”

1 ¾”

➤ **Step Two:** $FLR = 2Q^2$

$$FLR = 2 \frac{(gpm)^2}{100}$$

$$FLR = 2 \frac{(gpm)^2}{100}$$

$$FLR = 2 \frac{(200)^2}{100} = 2$$

$$FLR = 2 \frac{(400)^2}{100} = 2$$

$$FLR(2 \frac{1}{2}”) = 2(2)^2$$

$$FLR(1 \frac{3}{4}”) = 2(4)^2$$

$$FLR (2 \frac{1}{2}”) = 2 \times 4 = 8$$

$$FLR(1 \frac{3}{4}”) = 2 \times 16 = 32$$

$$FLR (2 \frac{1}{2}”) = 8$$

$$FLR(1 \frac{3}{4}”) = 32$$

➤ **Step Three:** $L = \frac{\text{total feet}}{100}$

$$L = \frac{200}{100}$$

$$L = \frac{200}{100}$$

$$L(2 \frac{1}{2}”) = 2$$

$$L(1 \frac{3}{4}”) = 2$$

➤ **Step Four:** $TFL = FLR(2 \frac{1}{2}”) \times L(2 \frac{1}{2}”) + FLR(1 \frac{3}{4}”) \times L(1 \frac{3}{4}”)$

$$TFL (2 \frac{1}{2}”) = 8 \times 2 + 32 \times 2$$

$$TFL (2 \frac{1}{2}”) = 16 + 64 \text{ psi}$$

$$TFL = 80$$

➤ **Step Five:** $**GL = 5 \times 30$

$$GL = 150 \text{ psi}$$

HINT

THE FIRST FLOOR IS NOT INCLUDED WHEN CALCULATING GL FOR STANDPIPES

$$PP = NP + TFL + SL^* + GL^{**}$$

$$PP = 100 + 80 + 25 + 150$$

$$PP = 355 \text{ psi}$$

HYDRAULIC SET-UPS AND CALCULATIONS

Sprinkler System

Example: Twenty heads are fused on the 8th floor; sprinkler system is supplied by two 500' lengths of 2 1/2" hose. PP = ?

Initial pump pressure = Maintain **150** psi at the pump until proper pump pressure can be determined.

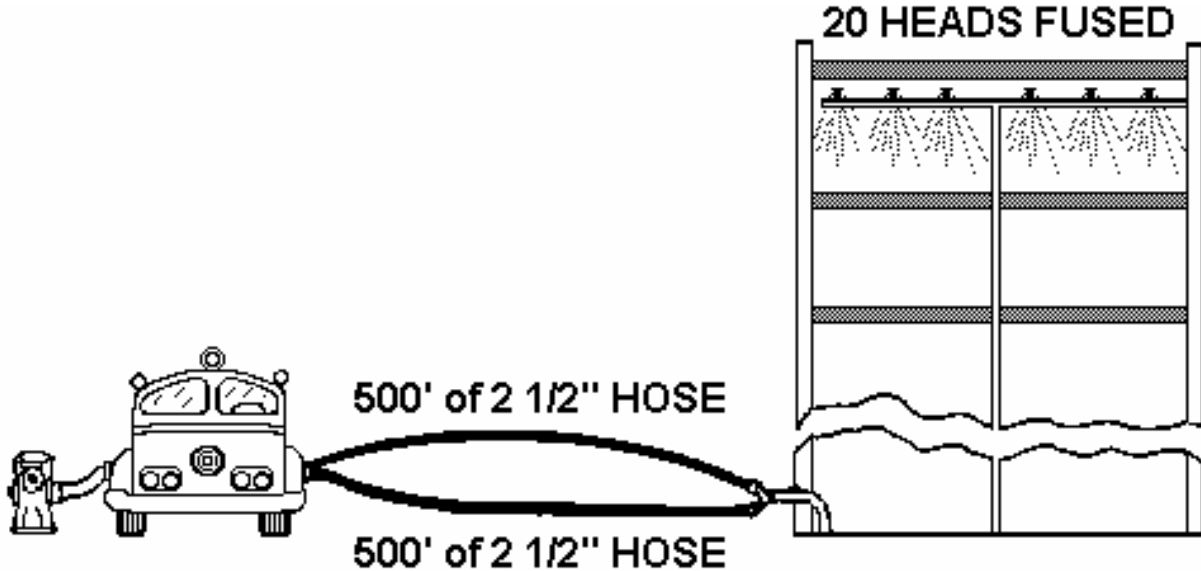

IN RAPID METHOD HYDRAULICS ALLOW **30 GPM** PER SPRINKLER HEAD.*

IN RAPID METHOD HYDRAULICS **25 PSI** CAN BE CONSIDERED AS EFFECTIVE SPRINKLER NOZZLE PRESSURE.**

ALLOW **25 PSI** LOSS FOR SPRINKLER SYSTEM (**SPR. L**)***

ALLOW **5 PSI** PER FLOOR FOR GRAVITY LOSS, INCLUDING THE FIRST FLOOR.***

- **Step One:** Flow = 30* x 20
- Flow = 600 gpm
- Flow through one line = $\frac{600}{2}$
- Flow through one line = **300** gpm

HINT

This lay is a version of the Siamese lay. Divide flow by number of supply lines and treat as a single line.

HYDRAULIC SET-UPS AND CALCULATIONS

Sprinkler System

➤ **Step Two:** $FLR = 2Q^2$

$$FLR = 2 \frac{(\text{gpm})^2}{100}$$

$$FLR = 2 \frac{(300)^2}{100} = 3$$

$$FLR = 2(3)^2$$

$$FLR = 2 \times 9 = 18$$

$$FLR = \mathbf{18 \text{ psi}}$$

➤ **Step Three:** $L = \frac{\text{total feet}}{100}$

$$L = \frac{500}{100}$$

$$L = \mathbf{5}$$

➤ **Step Four:** $TFL = FLR \times L$

$$TFL = 18 \times 5$$

$$TFL = \mathbf{90 \text{ psi}}$$

➤ **Step Five:** $**GL = 5 \times 8$

$$GL = \mathbf{40 \text{ psi}}$$

$$\mathbf{PP = NP^{**} + TFL + Spr. L^{***} + GL^{****}}$$

$$\mathbf{PP = 25 + 90 + 25 + 40}$$

$$\mathbf{PP = 180 \text{ psi}}$$

HYDRAULIC SET-UPS AND CALCULATIONS

Foam Appliance and Application

Example: 1 1/2", 125 gpm foam eductor
1 1/2", 125 gpm foam nozzle
200' of 1 3/4" between eductor and the foam nozzle
PP = **200** psi

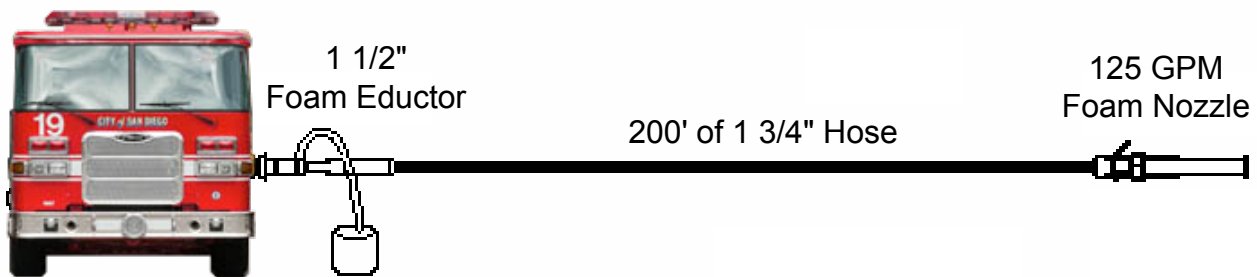

NOTE: NO HYDRAULIC CALCULATIONS FOR ANY 1 3/4" FOAM LAY UP TO 600 FEET.

ALWAYS PUMP 200 PSI.

HYDRAULIC SET-UPS AND CALCULATIONS

Foam Appliance and Application

Example: 400' of 2 1/2" hose, connected to a 1 1/2" foam eductor with 200' of 1 3/4" hose with a 125 gpm foam nozzle.

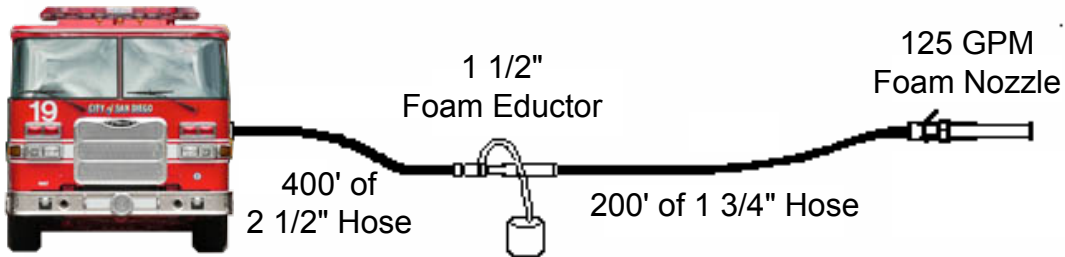

➤ **Step One:** Flow = 125 gpm

➤ **Step Two:** $FLR = 2Q^2$

$$FLR = 2 \frac{(gpm)^2}{100}$$

$$FLR = 2 \frac{(125)^2}{100} = 1.25$$

$$FLR (2 \frac{1}{2} ") = 2(1.25)^2$$

$$FLR (2 \frac{1}{2} ") = 2 \times 1.56 = 3.2$$

Round off 3.2 to = 3

➤ **Step Three:** $L(2 \frac{1}{2} ") = \frac{\text{total feet}}{100}$

$$L(2 \frac{1}{2} ") = \frac{400}{100}$$

$$L(2 \frac{1}{2} ") = 4$$

➤ **Step Four:** $TFL = FLR (2 \frac{1}{2} ") \times L$

$$TFL = 3 \times 4 = 12 \text{ psi}$$

HINT

FOR FOAM CALCULATIONS, 200 POUNDS FOAM SYSTEM LOSS IS USED FROM THE EDUCTOR TO THE NOZZLE.

$$\begin{aligned} PP &= TFL + 200 \\ PP &= 12 + 200 \\ PP &= 212 \text{ psi} \end{aligned}$$

HYDRAULIC SET-UPS AND CALCULATIONS

Foam Appliance and Application

Example: 2 100' of 2 ½" hose to Foam 28, Foam 28 has 2 100' lengths of 2 ½" connected to a pre-plumbed Ladder pipe with a 1000 gpm fog at 80' elevation.

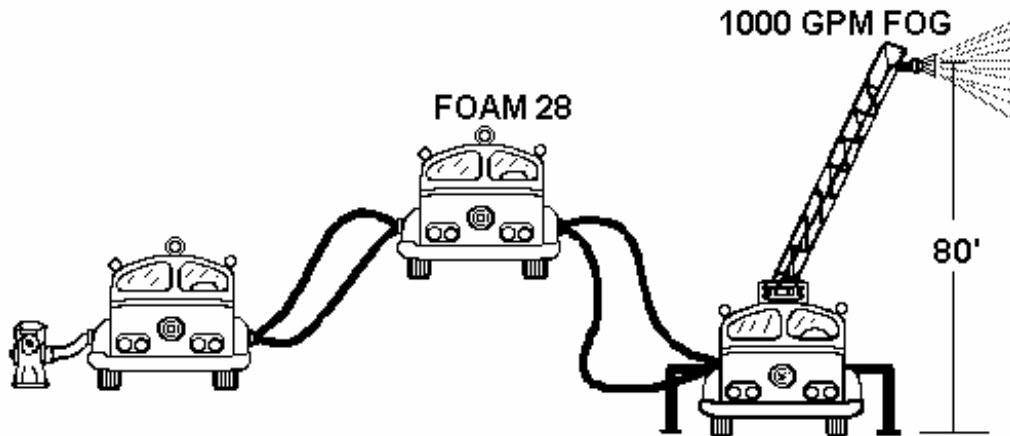

ALLOW 25 PSI LOSS FOR LADDER SYSTEM LOSS (LSL)***

ALLOW 15 PSI LOSS FOR FOAM 28 APPLIANCE LOSS (AL)***

➤ **Step One:** Flow = 1000 gpm

$$\text{Flow through one line} = \frac{1000}{2} = 500$$

$$\text{Flow per line} = 500 \text{ gpm}$$

➤ **Step Two:** FLR = $2Q^2$

$$\text{FLR} = 2 \frac{(\text{gpm})^2}{100}$$

$$\text{FLR} = 2 \frac{(500)^2}{100} = 5$$

$$\text{FLR} = 2(5)^2$$

$$\text{FLR} = 2 \times 25 = 50$$

$$\text{FLR} = 50$$

HYDRAULIC SET-UPS AND CALCULATIONS

Foam Appliance and Application

➤ **Step Three:** $L = \frac{\text{total feet}}{100}$

$$L = \frac{200}{100}$$

$$L = 2$$

HINT

1 LENGTH FROM THE ENGINE TO
FOAM 28, ANOTHER 1 LENGTH
FROM FOAM 28 TO THE TRUCK

➤ **Step Four:** $TFL = FLR \times L$

$$TFL = 50 \times 2 = 100 \text{ psi}$$

$$TFL = \mathbf{100 \text{ psi}}$$

$$PP = NP + AL + TFL + GL + LSL$$

$$PP = 100 + 15 + 100 + 40 + 25$$

$$PP = \mathbf{280 \text{ psi}}$$

HYDRAULIC SET-UPS AND CALCULATIONS

Relay Pumping Operations

Relaying of water can be accomplished when the activities of personnel and equipment involved are coordinated by the officer in charge, and upon receipt of specific information such as:

- Amount of water needed to extinguish the fire.
- Size and length of available hose.
- Apparatus available for pumping purposes.
- Time required setting up the relay.
- Maximum distance one pumper can deliver the gpm.
- Topography of the district over which relay is to be made.

The quantity of water (gpm) needed to effectively handle the situation must be estimated, because every succeeding phase of the relay will be governed by this estimate.

Since friction loss in hose used for relays will be one of the factors determining the distance between pumpers, the largest hose available should be used to minimize the number of pumpers required in the relay.

The distance from the water supply to the fire is secondary in estimating the amount of hose required for the relay. Primarily, it is the length of hose between individual pumpers that must be determined.

The hose line or lines leading to the fire from the last pump do not materially effect relay operations, and there is no need for them to enter relay computations. The operator of this pump may assume it is connected to a water supply for the purpose of extinguishing the fire.

The condition of the hose will also have an effect on the length of hose lines between pumps. **The pump pressure of the pumps in the relay should not exceed the pressure of the annual hose test.**

HYDRAULIC SET-UPS AND CALCULATIONS

When calculating pump pressure to be pumped by a relay pumper, **an intake pressure of 20 psi must be maintained** at the next pumper in line. On this basis the pressure that the hose can withstand, minus intake pressure, could be used to overcome friction loss and gravity loss, if it exists. **(250 - 20 = 230 psi)**

With friction loss rate determined, as a result of the gpm flow, the maximum amount of hose between pumps, without exceeding the maximum pump pressure, can be determined.

When distance is not a determining factor, (short relays) a pump pressure less than maximum could provide sufficient intake pressure at the next pump in line.

It is logical to expect pumpers of varying capacities to be used in each relay operation. It must be considered that the capacity of a pump diminishes as the pump pressure exceeds a certain pressure. Class A pumps will deliver about one half of capacity at 250 psi PP. Low discharge capacity compared to those of high discharge capacity should be taken into consideration. **The largest capacity pumper should be placed at the source of supply.**

More time will be needed to complete a relay than would be necessary to make a regular hose lay. This unavoidable delay should be considered in determining how large the fire will be by the time relayed water is available.

Differences in elevation between water supply and the nozzle will have a decided effect on the placement of pumpers in the relay, and also upon the total number required.

It is now evident that several things must be considered to keep within the maximum allowable pump pressure:

- Total friction loss developed by the quantity of water flowing, which has to be overcome by the pump.
- The gravity loss or gravity gain, if it exists.
- The intake pressure at the next pump in line.

HYDRAULIC SET-UPS AND CALCULATIONS

After the size and number of hose lines are decided upon, the number of pumps necessary to transport the desired flow to the pump engaged in the fire fighting can best be determined by the following formula:

$$\text{Number of pumps} = \frac{\text{TFL} + \text{GL (or)} - \text{GG}}{\text{Maximum PP} - \text{IP}}$$

Example: In a relay operation 1000 gallons per minute will be required to extinguish a barn fire. Three thousand feet of 4" hose will be used to transport water from the source to the pumper at the fire scene, which is 100 feet above the water source. How many pumpers will be needed to complete this lay? Hose is tested to 300 psi.

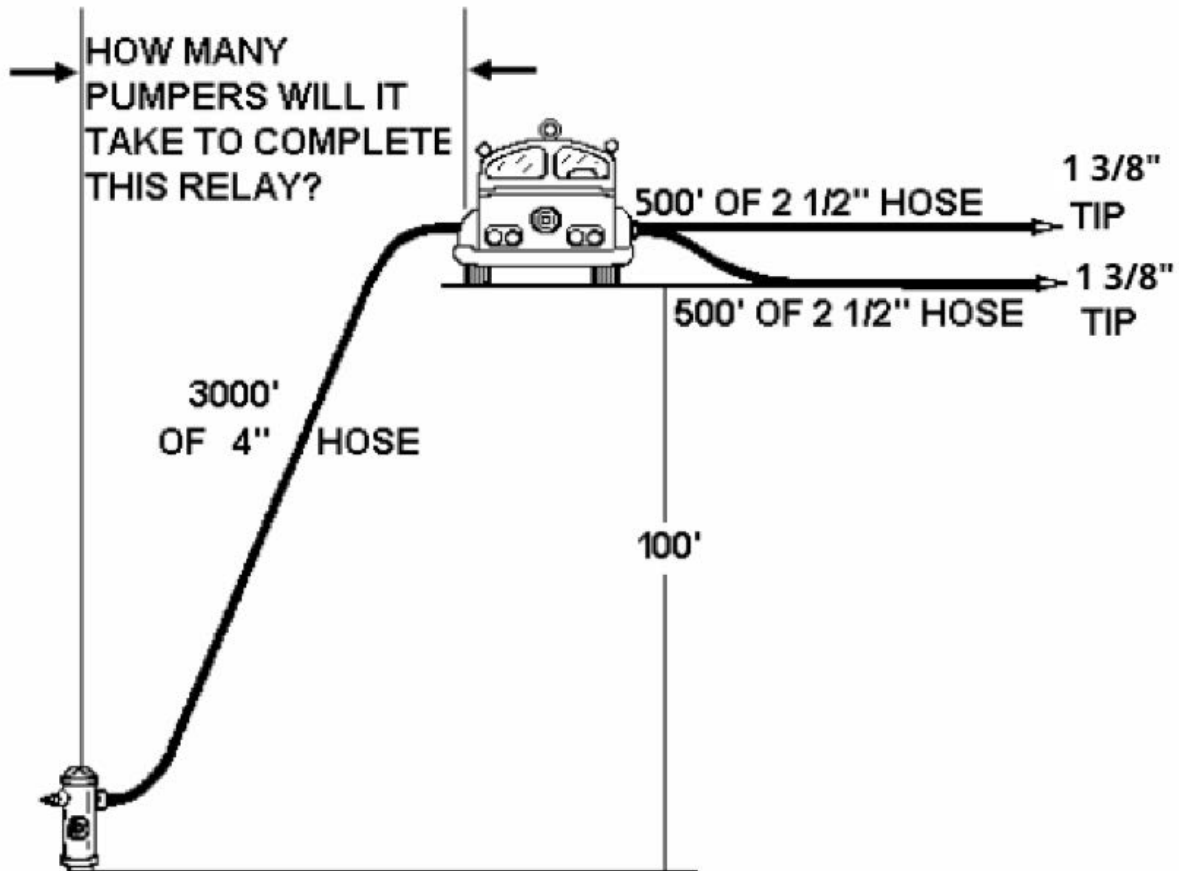

HYDRAULIC SET-UPS AND CALCULATIONS

➤ **Step One:** gpm = 1000

➤ **Step Two:** EF = Factor x gpm

$$EF = .25 \times 1000$$

$$EF = 250 \text{ gpm}$$

$$FLR = \mathbf{13} \text{ psi}$$

➤ **Step Three:** $L = \frac{\text{total feet}}{100}$

$$L = \frac{3000}{100}$$

$$L = \mathbf{30}$$

➤ **Step Four:** TFL = FLR x L

$$TFL = 13 \times 30$$

$$TFL = \mathbf{390} \text{ psi}$$

➤ **Step Five:** GL = .5 x 100

$$GL = \mathbf{50} \text{ psi}$$

$$\text{Total Pressure} = TFL + GL$$

$$\text{Total Pressure} = 390 + 50$$

$$\text{Total Pressure} = \mathbf{440}$$

$$\text{No. pumps} = \frac{TFL \pm GL}{\text{Maximum PP} - \text{IP (intake pressure)}}$$

$$\text{No. pumps} = \frac{390 + 50}{300 - 20}$$

$$\text{No. pumps} = \frac{440}{280} =$$

1.6 or 2 pumps

Using the above formulas, 2 pumps would be required for the relay to keep from pumping an excessive pressure.

HYDRAULIC SET-UPS AND CALCULATIONS

Example: Assuming the pumps are equidistant and the rise in elevation is equal between them, the distance between pumps = $\frac{3000}{2} = 1500$ feet. PP = ?

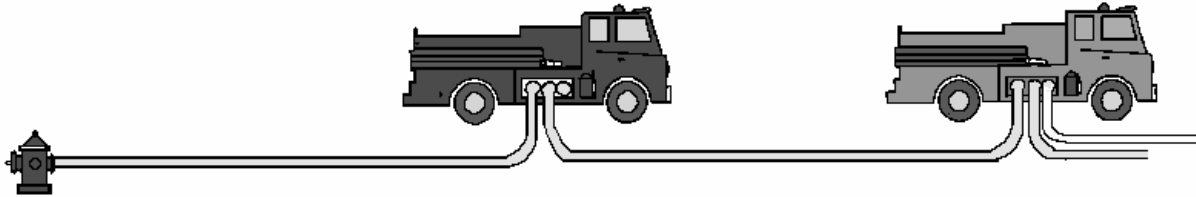

FLR = 13 psi

TFL = FLR x L

TFL = 13 x 15

TFL = **195 psi**

Head = $\frac{\text{Total elevation}}{\text{No. pumps}}$

Head = $\frac{100}{2}$

Head = 50

GL = .5 x H

GL = .5 x 50

GL = **25 psi**

PP = TFL + GL + IP
PP = 195 + 25 + 20
PP = 240 psi

240 psi would be the proper pressure for each pump in the relay to furnish the last pump doing the pumping for the fire.

HYDRAULIC SET-UPS AND CALCULATIONS

Determine Maximum length Hose for a given GPM.

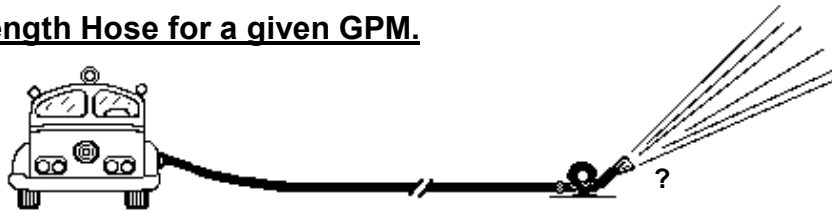

What is the maximum number of feet of 2 ½” (red) hose you can use when flowing a 500 gpm SOF nozzle on an appliance?

Step One: Information necessary to calculate -

The GPM of the nozzle = **500 gpm.**

The nozzle pressure (**NP**) for SOF is **100 psi.**

Appliance Loss (**AL**) is **15 psi.**

100 + 15 = the pressure needed at the appliance to have an effective stream.

Maximum pump pressure is limited to the maximum service test pressure for the hose used. Since 2 ½” (red) hose is used in this lay, the maximum pump pressure is **300 psi.**

Step Two: Calculate the friction loss rate (**FLR**).

$$FLR = 2Q^2$$

$$Q = \text{gpm} \div 100$$

$$FLR = 2Q^2$$

$$FLR = 2 \frac{(\text{gpm})^2}{100}$$

$$FLR = 2 \frac{(500)^2}{100}$$

$$FLR = 2 \times 5^2$$

$$FLR = 2 \times 25$$

$$FLR = 50$$

Step Three: Subtract pressure needed at appliance (100 NP + 15 AL = **115**) from maximum pressure (Hose test pressure is **300 psi**)

to determine maximum TFL available.

$$300 - 115 = \mathbf{185 \text{ TFL available}}$$

Step Four: Divide FLR (50) into 185 to determine L.

$$185 \div 50 = 3.7$$

Round off to **3.5 lengths of 2 ½” hose or 350’.**

NOTE:
Round off to ½ (or 50 foot) lengths of hose and DO NOT round up.

Blank Page

HYDRAULIC SET-UPS AND CALCULATIONS

EXAMPLE: How many gpm can you flow from a hydrant with 100 lbs. static pressure through 450 feet of 2 1/2" hose?

➤ **Step One:** Determine Length of hose

$$\frac{450}{100} \quad L = 4.5$$

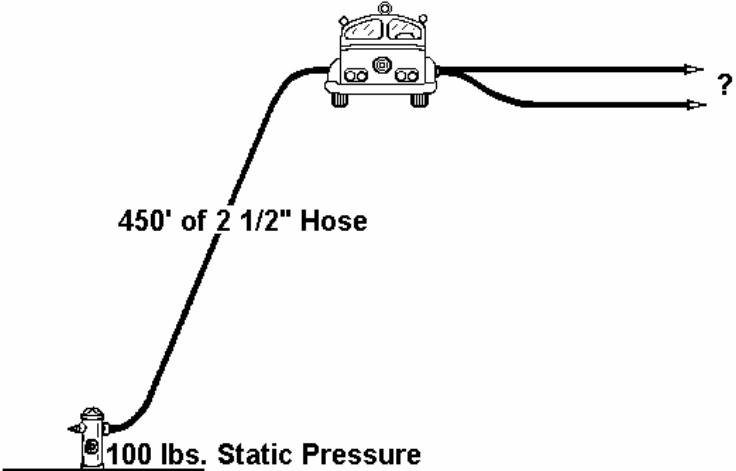

➤ **Step Two:** Determine Available Pressure loss through each length

Subtract intake pressure
(20 lbs) from hydrant
pressure $100 - 20 = 80$

➤ **Step Three:** Determine FLR per length

$$80 \div 4.5 = 18$$

$$\text{FLR} = 18$$

<p>Compare FLR in the Friction Loss Table or calculate $2Q^2$ in reverse.</p> <p>$18 \div 2 = 9$</p> <p>$\sqrt{9} = 3$</p> <p>$Q = 3 \times 100$</p> <p>Estimated GPM = 300</p>

Around 300 GPM can be expected from a 100 lb. Hydrant with 450 feet of supply hose.

ADDITIONAL INFORMATION

Fire Pump Capacities

Fire pumps now encountered on the San Diego Fire Department are of the centrifugal type. ISO (Insurance Service Organization) rates centrifugal fire pumps as standard from 500 to 1500 gpm. Acceptable modern pumps can deliver capacity discharge at 150 psi pump pressure from draft (10' lift) at sea level. Theoretical variations from capacity discharge can be computed by the application of the following formula:

$$PD = \frac{RC \times RP}{GPM}$$

Where:

PD = Pump discharge

RC = Rated capacity

RP = Rated pressure

GPM = Given pressure

Example: Theoretically, how many gpm can a pumper rated at 1000 gpm and at 150 psi Pump Pressure deliver at 200 psi?

Solution: $PD = \frac{RC \times RP}{GPM}$

$$PD = \frac{1000 \times 150}{200}$$

$$PD = 750 \text{ gpm}$$

- Note:**
1. Now that the discharge has been determined as 750 gpm, the number of lines that can be used can be computed by knowing nozzle gpm and NP.
 2. Operating at a pressure lower than 150 psi could result in discharge of greater than capacity.
 3. Pump discharge could be increased if connected to a hydrant, due to positive pressure on the intake side of the pump.
 4. Net pump pressure is pump pressure minus intake pressure.

ADDITIONAL INFORMATION

Fire Pump Capacities

Example: An apparatus connected to a fire hydrant is supplying several hose lines. Pump pressure reads 160 psi, intake pressure reads 20 psi on the compound gauge. What is the net pump pressure?

Solution: Net PP = PP - Intake pressure
Net PP = 160 - 20
Net PP = 140 psi

Estimating Available Flow from Hydrant

The ability to calculate the available flow (gpm) remaining in a hydrant can be of great advantage to both pump operator and the command officer, particularly at the fire ground, as well as in pre-planning surveys. REMEMBER that to be an efficient firefighter you should know as much about the water supply in your district as possible prior to an emergency.

To estimate the available flow from a hydrant the rule is: determine the percentage of drop between static (at rest) and residual (in motion) pressures.

This percentage of drop will indicate the estimated available flow:

- 10 % drop, 3 more like volumes
- 15 % drop, 2 more like volumes
- 25 % drop, 1 more like volume.

Therefore, to estimate the available flow from a hydrant, the following must be applied:

- Note the static pressure on the compound gauge after the hydrant has been opened to let water into the pump, but before opening any discharge valves.
- Note the residual pressure on the compound gauge after getting the line into operation at the proper pump pressure; and

ADDITIONAL INFORMATION

Estimating Available Flow from Hydrant

- Determine the percentage of drop.

Example: The static pressure on the compound gauge when the hydrant is delivering water into the pump is 60 psi. When the first line (250 gpm nozzle) is put into operation, the residual pressure is 54 psi. Estimate the remaining available gpm flow.

Solution: With a decrease from static pressure of 60 psi to a residual pressure of 54 psi (a drop of 6 psi), the percentage of drop is $6 \div 60 = .1$ or **10 percent**; therefore, 3 more like volumes is the estimated available flow, or a total estimated flow of 4 volumes (1000 gpm total).

Estimating Static Pressure

Estimating static pressure if it was not noted when the hydrant was opened, will usually be impractical because of allowable time. However, if it is deemed necessary, the following procedure may be used:

- Note the flowing pressure on the compound gauge with the first line in operation.
- Place another nozzle delivering the same gpm into operation and note the drop in flow pressure.
- Divide the drop pressure by 2 and add to the flow pressure when the first line was in operation. This is the estimated static pressure.

Example: A line delivering 160 gpm is put into operation, and the residual pressure on the compound gauge reads 68 psi. A second line delivering the same gpm is placed into operation and the residual pressure now reads 44 psi. Estimate the remaining available flow.

ADDITIONAL INFORMATION

Estimating Static Pressure – Available Flow

Solution: First, to estimate the static pressure with a decrease in residual pressure of 24 psi (from 68 psi to 44 psi), divide the drop in pressure by 2 which equals 12 psi. This can then be added to the residual pressure that was noted when the first line was put into operation. We now have $68 + 12$, which equal an estimated static pressure of 80 psi.

Next, to estimate the remaining available flow with a decrease from static to Residual pressure of 12 psi (80 to 68), the percentage of drop is $12/80$ or 15 %; therefore, 2 more like volumes is the estimated available flow, or a total estimated flow of 3 like volumes.

Note: When pumping at a fire, the hydrant residual pressure should never drop from positive to negative, preferably it should be at least 20 psi whenever possible.

ADDITIONAL INFORMATION

How to Estimate Quantities of Water

- To determine the capacity in gallons of water in a rectangular container or on a floor of a building if the dimensions are in feet, use the formula:

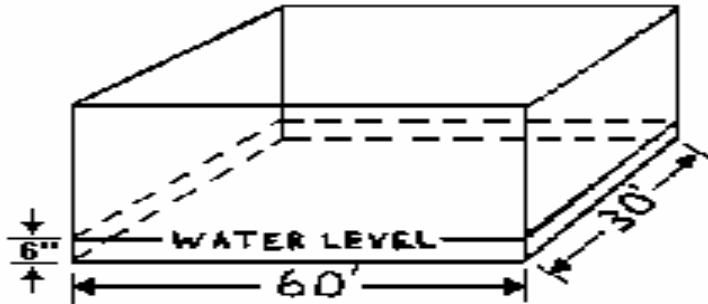

$$C = L \times W \times H \times 7.5$$

C = Capacity in gallons

L = Length in feet

W = Width in feet

H = Height in feet

7.5 = gallons per cubic foot

$$C = 60 \times 30 \times .5 \times 7.5$$

$$C = 6750 \text{ gallons}$$

Example: Determine approximate capacity of rectangular tank 20' x 15' x 5'.

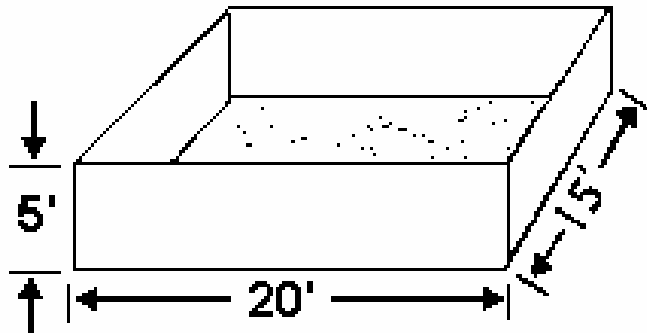

$$C = L \times W \times H \times 7.5$$

$$C = 20 \times 15 \times 5 \times 7.5$$

$$C = 11,250 \text{ gallons}$$

ADDITIONAL INFORMATION

How to Estimate Quantities of Water

- The rapid method for finding the approximate capacity of water in gallons in a cylindrical tank, when the dimensions are in feet is as follows:

$$C = 6d^2 \times H$$

C = Capacity in gallons

6 = Constant

d = Diameter in feet

H = Height of water in feet

Example: Determine approximate capacity of tank 20' in diameter by 5' deep.

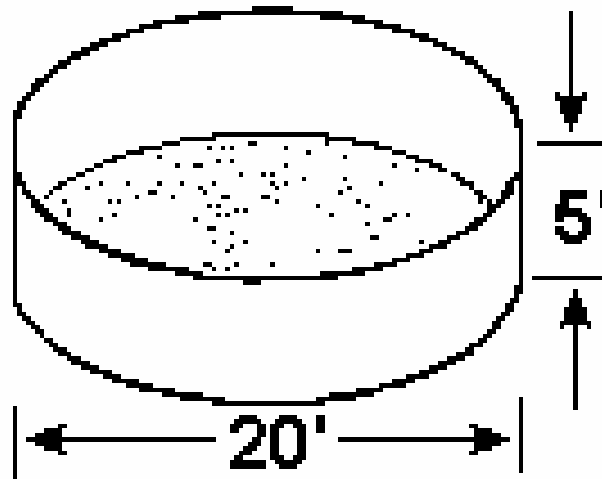

$$C = 6d^2 \times H$$

$$C = 6(20)^2 \times H$$

$$C = 6(400) \times 5$$

$$C = 2400 \times 5$$

$$C = \mathbf{12,000} \text{ gallons}$$

For greater accuracy, subtract 2 percent of the total;

Example: $12,000 \times .02 = 240$ then;

$$12,000 - 240 = \mathbf{11,760} \text{ gallons.}$$

ADDITIONAL INFORMATION

How to Estimate Weight of Water

Example: Determine the weight of water in a room 60' by 30' by 6" deep.

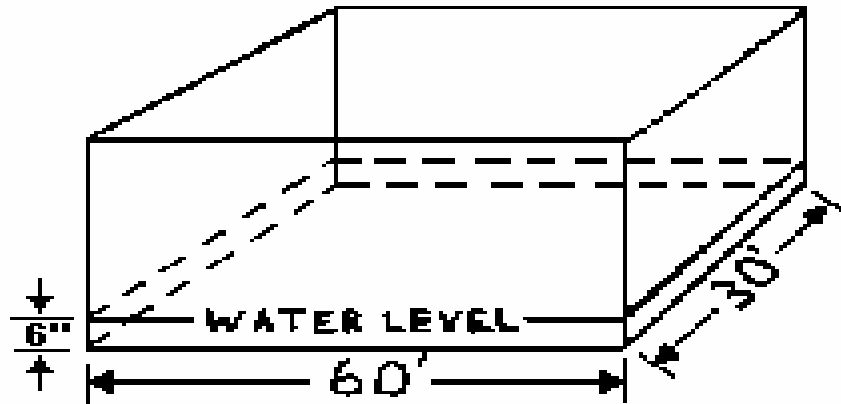

$$\text{Weight} = L \times W \times H \times 62.5$$

$$\text{Weight} = 60 \times 30 \times .5 \times 62.5$$

$$\text{Weight} = 56,250 \text{ pounds}$$

$$\text{Weight} = \frac{56,250}{2000}$$

$$\text{Weight} = 28 \frac{1}{8} \text{ tons}$$

ADDITIONAL INFORMATION

How to Estimate Weight of Water

- To determine weight;
 1. multiply the number of gallons by 8.35 pounds or
 2. multiply the number of cubic feet by 62.5 pounds.

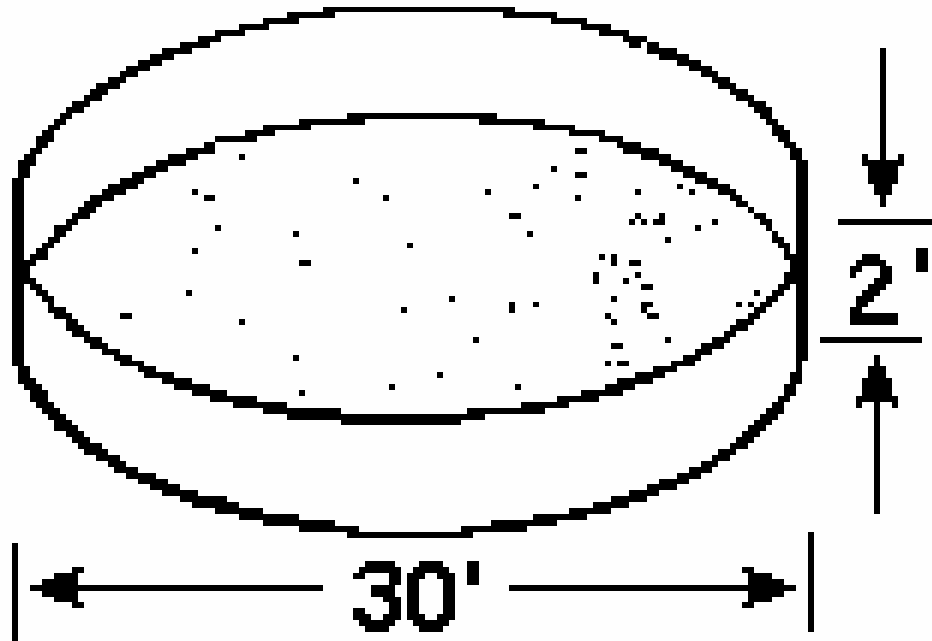

Example: Determine the weight of water in a cylindrical tank 30' in diameter and 2' deep:

$$\text{Weight} = 6d^2 \times H \times 8.35$$

$$\text{Weight} = 6(900) \times 2 \times 8.35$$

$$\text{Weight} = \mathbf{90,180 \text{ pounds}}$$

$$\text{Weight} = \frac{90,180}{2000}$$

$$\text{Weight} = \mathbf{45 \text{ tons}}$$

ADDITIONAL INFORMATION

Available Flow from a Hydrant

The formula, $\text{gpm} = 27 \times d^2 \times \sqrt{P}$, is used to find the amount of water flowing from any non-restricted opening such as a hydrant port or the end of a hose (without a nozzle).

27 = Constant

d = Diameter of opening

P = Pressure per square inch using pitot gauge

Example: What is the approximate gpm flow from **two** 2 1/2" hydrant ports flowing simultaneously? Residual pressure is 25 psi.

$$\text{gpm} = 27 \times d^2 \times \sqrt{P} \times 2$$

$$\text{gpm} = 27 \times (2.50)^2 \times \sqrt{25} \times 2$$

$$\text{gpm} = 27 \times 6.25 \times 5 \times 2$$

$$\text{gpm} = 1687.5 \text{ or } 1690 \text{ gpm}$$

For pressure (P) go to the nearest number from which the square root can be easily extracted, such as 49 for 50.

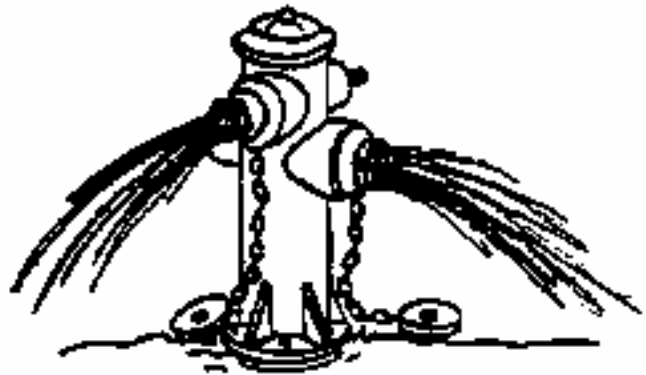

ADDITIONAL INFORMATION

Weight of Water Delivered

It is useful to know that a standard fire stream, 250 gpm, represents approximately one ton of water per minute delivered into a building or structure. Consideration should be given to the safety of personnel due to the possibility of structural collapse, and provision made for the removal of water from the building.

Below is a table relating nozzle size to the approximate weight of water being delivered per minute.

NOZZLE	PSI	GPM	WATER PER MINUTE
1 1/8"	50	270	1 1/4 ton
1 1/4"	80	400	1 1/2 ton
1 1/2"	80	600	2 1/2 ton
1 3/4"	80	800	3 1/3 ton
2"	80	1100	4 1/2 ton

Master Stream

A master stream can be defined as a large caliber fire stream too heavy for convenient or safe manual operation and therefore discharged through a monitor nozzle, deluge set, ladder pipe, portable monitor, or turret. It commonly produces a fire stream in excess of 400 gpm, and may consist of two or more hose lines siamesed into a single heavy stream appliance.

ADDITIONAL INFORMATION

Nozzle Reaction

Water being discharged from a nozzle under pressure is not unlike the thrust from a jet aircraft engine, in that it causes an opposite reaction. The danger of this reaction upon a firefighter handling the nozzle cannot be over emphasized; especially the reaction encountered from a nozzle on a long lay with high engine pressure to overcome friction. The engine pressure is built up right to the nozzle when the water is static. The reaction is greatest when the nozzle is first opened.

This reaction can be calculated in total force by a formula if the diameter of the orifice is known, and the pressure at the orifice is known. The force will be in pounds.

$$NR = 1.5 \times d^2 \times NP$$

1.5 = a constant

d² = Diameter of orifice squared

NP = Pressure at the orifice when flowing

Example: What is the nozzle reaction from a 2" tip with 80 psi NP?

$$NR = 1.5 \times d^2 \times NP$$

$$NR = 1.5 \times d^2 \times 80$$

$$NR = 480 \text{ lbs. (not psi)}$$

Size limits for hose control.

- Appliance mandatory for straight tip greater than 1 1/8"
- Flowing 250 gpm or greater = Two person operation

DEFINITIONS, MEASUREMENTS, AND CHARTS

Abbreviations and Definitions

AL	Appliance Loss - Appliance loss is the amount of energy (psi) lost in the turbulence of the water flowing through an appliance.
C	Capacity in gallons
d	Diameter
EF	Equivalent Flow - The amount of water flowing through a hose that is not a 2 1/2" hose which creates the same friction loss rate as that created in 2 1/2" hose.
F	Factor
FLR	Friction Loss Rate - The amount of energy or pounds pressure (psi) lost due to the turbulence of water in contact with the lining of a hose. It is measured in 100' lengths of 2 1/2" hose.
GG	Gravity Gain - The amount of pressure (psi) gained when going down
GL	Gravity Loss - The amount of pressure (psi) lost when pushing water up
gpm	Gallons Per Minute
H	Head in feet – a column of water measured in feet
Hg	Mercury - Measured in inches. Thirty inches of mercury is equal to 14.7 psi.
HP	Head Pressure in psi - $H \times .434$
IP	Intake Pressure - The pressure exerted by a water source on the intake side of a pump.
L	Length of hose equal to p 100'
LSL	Ladder System Loss – 25 lbs for Snorkel and Pre-plumbed ladder system loss
NP	Nozzle Pressure - Pressure at which water leaves the nozzle
NR	Nozzle Reaction - Water leaving a nozzle produces a reaction equal to $1.5 \times d^2 \times NP$
PP	Pump Pressure - Pressure (psi) at which water is discharged from the pump
psi	Pounds Per Square Inch
RS	Residual Pressure - Water pressure (psi) remaining when a valve or hydrant is open and the water is flowing
Spr. L	SPRinkler System Friction Loss - 25 psi
SL	Standpipe Friction Loss - 25 psi
T	Ton - 2000 pounds
TFL	Total Friction Loss

DEFINITIONS, MEASUREMENTS, AND CHARTS

Measurements

- Atmospheric pressure at sea level is 14.7 psi = 30 inches of mercury = 33.9 feet of water. Therefore, 1 inch of mercury = 1.13 feet of water.
- One gallon of water occupies 231 cubic inches and weighs 8.35 pounds.
- 1 Cubic foot = 1728 cubic inches.
- 1 Cubic foot of water weighs 62.5 pounds and contains 7.5 gallons.

Nozzle and Gallons per Minute Flow

In fire ground hydraulics the flow from nozzles at standard pressures will be listed. The friction loss rates will be in the form of a table for reference purposes.

1" NOZZLES

GPM

1" Select-O-Flow (SOF)	20-40-60
1" Select-O-Flow SOF (Redline)	5-10-24-40

1 ½" NOZZLES

1 ½" Select-O-Flow SOF (Hi Rise Pack)	30-60-95-125-150-175-200
1 ½" Select-O-Flow SOF (Hi Rise Pack)	30-60-95-125-150-180-200
1 ½" Select-O-Flow (SOF)	30-60-95-125
1 ½" Select-O-Flow (SOF)	95-125-150-200

2 ½" NOZZLES

2 ½" Select-O-Flow (SOF)	125-150-200-250
2 ½" Select-O-Flow (SOF)	500-750-1000-1250
2 ½" Select-O-Flow (SOF)	750-1000-1250
2 ½" Turbojet Master	1000

DEFINITIONS, MEASUREMENTS, AND CHARTS

SMOOTH BORE TIPS - Hand Lines

NP

GPM

3/16"	TIPS FOR WILDLAND USE	50 psi	7
1/4"		50 psi	13
3/8"		50 psi	30

When calculating gpm round off to the nearest **1** gpm.

1/2"	50 psi	50
5/8"	50 psi	80
3/4"	50 psi	120
7/8"	50 psi	160
1"	50 psi	210
1 1/8"	50 psi	270
1 1/4"	50 psi	330

When calculating gpm round off to the nearest **10** gpm.

SMOOTH BORE TIPS - Appliances

NP

GPM

1 1/4"	80 psi	400
1 3/8"	80 psi	500
1 1/2"	80 psi	600
1 3/4"	80 psi	800
2"	80 psi	1100

When calculating gpm round off to the nearest **100** gpm.

DEFINITIONS, MEASUREMENTS, AND CHARTS

*** REDLINE**

<u>GPM</u>	<u>PP</u>
5	106 psi
10	121
24	218
30	285
35	350
40	426

*** EF FACTORS (x GPM)**

3/4"	gpm	x	25
1"	gpm	x	9
1 1/2"	gpm	x	3.6
1 3/4"	gpm	x	2
3"	gpm	x	.67
3 1/2"	gpm	x	.4
4"	gpm	x	.25

*** MISC. INFORMATION**

G	=	+ .5 / ft or 5 lbs per floor
AL	=	15 psi
LSL	=	25 lbs for snorkel & ladder
SL	=	25 + 5 lbs per floor – 1
SPR. L	=	25 + 5 lbs per floor
SPR.	=	30 GPM per HEAD
FOG NP	=	100 psi
FOAM	=	100 AL + 100 NP (60 gpm MAX)
FOAM	=	200 PSI UP TO 600'

*** 1 3/4" CROSS LAY**

<u>150 gpm</u>	<u>175 gpm</u>	<u>200 gpm</u>
100' - 118 PP	125 PP	132 PP
150' - 127 PP	138 PP	148 PP
200' - 136 PP	150 PP	164 PP

*** STRAIGHT TIPS**

<u>SIZE</u>	<u>GPM</u>	<u>NP</u>
3/8"	30	50 psi
1/2"	50	50 psi
7/8"	160	50 psi
1"	210	50 psi
1 1/8"	270	50 psi
1 1/4"	330	50 psi
1 1/4"	400	80 psi
1 3/8"	500	80 psi
1 1/2"	600	80 psi
1 3/4"	800	80 psi
2"	1100	80 psi

*** IMMEDIATE PP**

HAND LINES

Nozzle Pressure + GL or - GG

ELEVATED STREAMS

150 psi

SPRINKLERS & STANDPIPES

150 psi

*** FORMULAS**

PP = NP + TFL (+ AL; + SL; + Spr. L; + GL; - GG)

TFL = FLR x L

FLR = $2Q^2$,
where Q = gpm ÷ 100

GPM = $30d^2 \sqrt{NP}$

NR = $1.5d^2 NP$

DEFINITIONS, MEASUREMENTS, AND CHARTS

Gallons per Minute and Friction Loss Tables

FRICITION LOSS RATE (FLR) FOR GPM THROUGH HOSE PER 100' LENGTH HOSE

2 1/2"	1"	1 1/2"	1 3/4"	3 1/2"	4"	FLR
				200	200	1
					250	1
100	11	28	50	250	400	2
110	12	31	55		450	2
120	13	34	60	300		3
130	14	36	65		500	3
140	15	39	70			4
150	17	42	75		600	5
160	18	45	80	400		5
170	19	48	85			6
180	20	50	90	450	700	6
190	21	53	95		750	7
200	22	56	100	500	800	8
210	23	59	105			9
220	24	62	110			10
230	25	64	115		900	11
240	26	67	120	600		12
250	28	70	125		1000	13
260	29	73	130			14
270	30	76	135			15
280	31	78	140	700	1100	16
290	32	81	145			17
300	33	84	150	750	1200	18
310	34	87	155		1250	19
320	35	90	160	800		20
330	36	92	165		1300	22
340	37	95	170			23
350	39	98	175		1400	25
360	40	101	180	900		26
370	41	104	185			27
380	42	106	190		1500	29
390	43	109	195			30
400	44	112	200	1000		32
410	45	115	205			34
420	46	118	210			35
430	47	120	215			37
440	48	123	220	1100	1750	39

HINT

For rapid calculations of 2 1/2" hose FLR.

GPM's between 180 and 320 subtract 12 from the first two numbers.

DEFINITIONS, MEASUREMENTS, AND CHARTS

Gallons per Minute and Friction Loss Tables

FRICITION LOSS RATE (FLR) FOR GPM THROUGH HOSE PER 100' LENGTH HOSE

2 1/2"	1"	1 1/2"	1 3/4"	3 1/2"	4"	FLR
450	50	126	225			41
460	51	129	230			42
470	52	132	235			44
480	53	134	240	1200		46
490	54	137	245			48
500	55	140	250	1250	2000	50
510	56	143	255			52
520	57	143	260	1300		54
530	58	148	265			56
540	59	151	270			58
550	60	154	275			61

3/4" gpm	EF to 2 1/2"	FLR
5	130	3
10	250	13
20	500	50
24	600	72
40	1000	200

NOTE: Please refer to equivalent flow information.

ANNUAL SERVICE TEST

Introduction

Fire Department pumpers are tested after any extensive repairs and annually. The following is intended to standardize the testing procedures. Services tests are based on the capacity specified for each apparatus. These capacities are in the original specifications.

General Information

Operations Battalion Chiefs will schedule all apparatus, including reserve apparatus, in their Battalion for an annual fire pump service test. Service tests will be scheduled and performed only when the Repair Facility is open.

Before going to test site (fire station 28) grease all discharge valves, check the gaskets and tighten all caps. Make sure all fluid levels are correct, i.e., engine oil, radiator, priming pump, etc.

Service Test

All of the tests will be accomplished at the test site. The service test for a Class "A" fire pump consists of the following:

- Dry vacuum
- Quick lift
- 100% capacity
- 10% overload
- 70% capacity
- 50% capacity
- Relief valve
- Monitor

ANNUAL SERVICE TEST

Positioning the Apparatus, Hose and Equipment

The crew will assist the Engineer in positioning the apparatus at the test pit. Set air brakes and place wheel block. Before any hook ups are made, the "dry vacuum" test will be done. The remove intake screens, hook-up hard sections, turn relief valve to highest setting. Lay proper lengths of fire hose for size of pump (see diagram) and place stream straightener and valve on outlet #1. A drip pan will be placed under primary pump oil discharge.

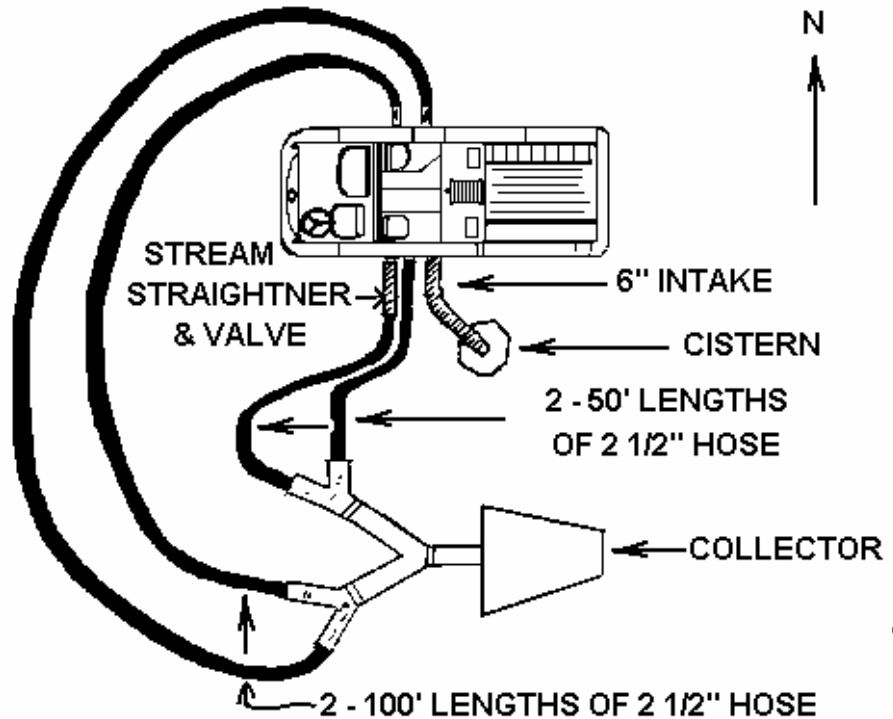

Test Procedures

- **Dry Vacuum** - Place pump-shifting lever in pump position, engage priming pump and draw at least 22 inches of mercury. After disengaging the primary pump a loss of no more than 10 inches of mercury in 1 minute will pass Quick Lift Test - Place pump shift lever in pump position, engage the primary pump at idle speed and advance the r.p.m. To proper priming r.p.m. (See individual apparatus manual). Water should be discharged in a maximum of **30 seconds for a 1,250-gpm pump or less**, and in a maximum of **45 seconds for 1,500 gpm pumps**.

ANNUAL SERVICE TEST

- **100% Capacity** - When a constant discharge of water is obtained, disengage priming pump, advance throttle, and open correct discharge valves for remaining hose lines. Engineer will adjust engine rpm and choke discharge valve(s) to obtain desired nozzle and pump pressure (see Pump Test Chart). Hold for 20 minutes. This is 150 psi.

- **10% Overload** - After completion of the 100% capacity test, a 10% overload test will be conducted. The test is 10% higher pressure at 100% gpm. This is 165 psi.

- **70% Capacity** - Procedures will be the same as 100% test, with the exception of pressure (200 psi) and nozzle size. This test will last 10 minutes.

- **50% Capacity** - Procedures will be the same as 100% test, with the exception of pressure (250 psi) and nozzle size. This test will last 10 minutes.

- **Relief Valve** - At the completion of the 50% test, the relief valve will be tested. To test the valve, set it at 150 psi, shutdown a like line. The pump pressure should not increase more than 30 psi.

- **Monitor** - Remove the nozzle and cap the opening. Tighten all fittings. Pressurize the monitor to 250 psi for one minute.

ADDITIONAL PRACTICE HYDRAULICS PROBLEMS**DETERMINE PUMP PRESSURE FOR THE FOLLOWING PROBLEMS****REFERENCE PAGE – 12 - 13**

1. 125 GPM SOF NOZZLE, 600' OF 2 ½" HOSE.
2. 150 GPM SOF NOZZLE, 550' OF 2 ½" HOSE.
3. 200 GPM SOF NOZZLE, 800' OF 2 ½" HOSE.
4. 250 GPM SOF NOZZLE, 650' OF 2 ½" HOSE.

REFERENCE PAGE – 14 - 15

5. ¾" TIP, HAND HELD, 400' OF 2 ½" HOSE.
6. 7/8" TIP, HAND HELD, 650' OF 2 ½" HOSE.
7. 1" TIP, HAND HELD, 800' OF 2 ½" HOSE.
8. 1 1/8" TIP, HAND HELD, 750' OF 2 ½" HOSE.

REFERENCE PAGE – 16 - 17

9. 125 GPM SOF NOZZLE, 600' OF 2 ½" HOSE, 60' ABOVE PUMP.
10. 150 GPM SOF NOZZLE, 300' OF 2 ½" HOSE, 20' ABOVE PUMP.
11. 200 GPM SOF NOZZLE, 650' OF 2 ½" HOSE, 80' ABOVE PUMP.
12. 250 GPM SOF NOZZLE, 850' OF 2 ½" HOSE, 100' ABOVE PUMP.

REFERENCE PAGE – 18 - 19

13. 125 GPM SOF NOZZLE, 400' OF 2 ½" HOSE, 50' BELOW PUMP.
14. 150 GPM SOF NOZZLE, 650' OF 2 ½" HOSE, 110' BELOW PUMP.
15. 200 GPM SOF NOZZLE, 350' OF 2 ½" HOSE, 70' BELOW PUMP.
16. 250 GPM SOF NOZZLE, 550' OF 2 ½" HOSE, 30' BELOW PUMP.

REFERENCE PAGE – 18 - 19

17. 30 GPM SOF NOZZLE, 600' OF 1 3/4" HOSE.
18. 60 GPM SOF NOZZLE, 350' OF 1 3/4" HOSE.
19. 95 GPM SOF NOZZLE, 300' OF 1 3/4" HOSE.
20. 125 GPM SOF NOZZLE, 100' OF 1 3/4" HOSE.
21. 150 GPM SOF NOZZLE, 700' OF 1 3/4" HOSE.
22. 175 GPM SOF NOZZLE, 450' OF 1 3/4" HOSE.
23. 200 GPM SOF NOZZLE, 450' OF 1 3/4" HOSE.

REFERENCE PAGE – 22- 23

24. DETERMINE PUMP & GATED PRESSURE – TWO 1 3/4" HANDLINES, LINE ONE – 125 GPM SOF NOZZLE, 450' OF 1 3/4" HOSE, LINE TWO – 125 GPM SOF NOZZLE, 600' OF 1 3/4" HOSE.
25. DETERMINE PUMP & GATED PRESSURE – TWO 1 3/4" HANDLINES, LINE ONE – 150 GPM SOF NOZZLE, 100' OF 1 3/4" HOSE, LINE TWO – 200 GPM SOF NOZZLE, 200' OF 1 3/4" HOSE.
26. DETERMINE PUMP & GATED PRESSURE – TWO 1 3/4" HANDLINES, LINE ONE – 125 GPM SOF NOZZLE, 450' OF 1 3/4" HOSE, LINE TWO – 125 GPM SOF NOZZLE, 600' OF 1 3/4" HOSE.
27. DETERMINE PUMP & GATED PRESSURE – TWO 1 3/4" HANDLINES, LINE ONE – 60 GPM SOF NOZZLE, 100' OF 1 3/4" HOSE, LINE TWO – 200 GPM SOF NOZZLE, 350' OF 1 3/4" HOSE.

REFERENCE PAGE – 24- 25

28. 30 GPM SOF NOZZLE, 200' OF 1 3/4" HOSE, ADD 250' OF 1 3/4" HOSE.
29. 60 GPM SOF NOZZLE, 100' OF 1 3/4" HOSE, ADD 200' OF 1 3/4" HOSE.
30. 125 GPM SOF NOZZLE, 200' OF 1 3/4" HOSE, ADD 350' OF 1 3/4" HOSE.
31. 150 GPM SOF NOZZLE, 350' OF 1 3/4" HOSE, ADD 350' OF 1 3/4" HOSE.

REFERENCE PAGE – 26- 27

32. 3/16" WILDLAND TIP, 600' OF 1 1/2" HOSE.
33. 1/4" WILDLAND TIP, 1000' OF 1 1/2" HOSE.
34. 3/8" WILDLAND TIP, 950' OF 1 1/2" HOSE.
35. 1/2" WILDLAND TIP, 750' OF 1 1/2" HOSE.

REFERENCE PAGE – 28- 29

- 36. 5 GPM SOF NOZZLE, 200' OF 1" HOSE.
- 37. 10 GPM SOF NOZZLE, 400' OF 1" HOSE.
- 38. 20 GPM SOF NOZZLE, 300' OF 1" HOSE.
- 39. 40 GPM SOF NOZZLE, 100' OF 1" HOSE.

REFERENCE PAGE – 30- 31

- 40. 5 GPM SOF NOZZLE, 100' OF 1" HOSE, AND 150' OF 3/4" REDLINE.
- 41. 10 GPM SOF NOZZLE, 100' OF 1" HOSE, AND 150' OF 3/4" REDLINE.
- 42. 40 GPM SOF NOZZLE, 100' OF 1" HOSE, AND 150' OF 3/4" REDLINE.

REFERENCE PAGE – 32- 33

- 43. 1 1/8" TIP HAND HELD ON 200' OF 2 1/2" HOSE, SUPPLIED BY TWO 2 1/2" x 450' SIAMESE HOSE LINES.
- 44. 250 GPM SOF ON 300' OF 2 1/2" HOSE, SUPPLIED BY TWO 2 1/2" x 350' SIAMESE HOSE LINES.
- 45. 1" TIP HAND HELD ON 150' OF 2 1/2" HOSE, SUPPLIED BY TWO 2 1/2" x 500' SIAMESE HOSE LINES.
- 46. 3/4" TIP HAND HELD ON 400' OF 2 1/2" HOSE, SUPPLIED BY TWO 2 1/2" x 250' SIAMESE HOSE LINES.

REFERENCE PAGE – 34- 35

- 47. ONE HAND HELD 1 1/8" TIP, ON 150' OF 2 1/2" HOSE, SUPPLIED BY TWO UNEQUAL 2 1/2' SIAMESE HOSE LINES, ONE 250' THE SECOND 350'.
- 48. 200 GPM SOF NOZZLE, ON 300 FEET OF 2 1/2" HOSE, SUPPLIED BY TWO UNEQUAL 2 1/2' SIAMESE HOSE LINES, ONE 150' THE SECOND 250'.

REFERENCE PAGE – 36 - 37 & 42- 43

- 49. TWO 150 GPM SOF NOZZLES EACH ON 400' OF 2 ½" HOSE, WYED OFF OF ONE 150' LENGTH OF 2 ½" SUPPLY LINE.
- 50. TWO 175 GPM SOF NOZZLES EACH ON 200' OF 2 ½" HOSE, WYED OFF OF ONE 300' LENGTH OF 2 ½" SUPPLY LINE.
- 51. TWO 1" TIPS, EACH ON 500' OF 2 ½" HOSE, WYED OFF OF ONE 200' LENGTH OF 2 ½" SUPPLY LINE.
- 52. TWO 1 1/8" TIPS, EACH ON 200' OF 2 ½" HOSE, WYED OFF OF ONE 100' LENGTH OF 2 ½" SUPPLY LINE.

REFERENCE PAGE – 38- 39

- 53. TWO 150 GPM SOF NOZZLES, ONE ON 200' OF 2 ½", THE SECOND ON 300' OF 2 ½" HOSE, WYED OFF OF ONE 100' LENGTH OF 2 ½" SUPPLY LINE.
- 54. TWO 175 GPM SOF NOZZLES, ONE ON 200' OF 2 ½", THE SECOND ON 350' OF 2 ½" HOSE, WYED OFF OF ONE 250' LENGTH OF 2 ½" SUPPLY LINE.
- 55. TWO ¾" TIPS, ONE ON 300' OF 2 ½", THE SECOND ON 450' OF 2 ½" HOSE, WYED OFF OF ONE 250' LENGTH OF 2 ½" SUPPLY LINE.
- 56. TWO 200 GPM SOF NOZZLES, ONE ON 100' OF 2 ½", THE SECOND ON 250' OF 2 ½" HOSE, WYED OFF OF ONE 100' LENGTH OF 2 ½" SUPPLY LINE.

REFERENCE PAGE – 40- 41

- 57. TWO STRAIGHT TIP NOZZLES, ONE IS 1" TIP ON 300' OF 2 ½", THE SECOND IS A 1 1/8" TIP ON 300' OF 2 ½" HOSE, WYED OFF OF ONE 100' LENGTH OF 2 ½" SUPPLY LINE.
- 58. TWO SOF NOZZLES, ONE IS 150 GPM SOF ON 150' OF 2 ½", THE SECOND IS A 250 GPM SOF ON 150' OF 2 ½" HOSE, WYED OFF OF ONE 400' LENGTH OF 2 ½" SUPPLY LINE.
- 59. TWO STRAIGHT TIP NOZZLES, ONE IS A ¾" TIP ON 350' OF 2 ½", THE SECOND IS A 1" TIP ON 350' OF 2 ½" HOSE, WYED OFF OF ONE 250' LENGTH OF 2 ½" SUPPLY LINE.

REFERENCE PAGE – 44- 45

- 60. TWO 300' x 1 3/4" HANDLINES WITH A 60 GPM SOF NOZZLE. THE TWO 1 3/4" LINES ARE WYED OFF OF ONE 400' LENGTH OF 2 1/2" SUPPLY LINE.
- 61. TWO 150' x 1 3/4" HANDLINES WITH A 175 GPM SOF NOZZLE. THE TWO 1 3/4" LINES ARE WYED OFF OF A 600' LENGTH OF 2 1/2" SUPPLY LINE.
- 62. TWO 150' x 1 3/4" HANDLINES WITH A 125 GPM SOF, THE TWO 1 3/4" LINES ARE WYED OFF OF A 600' LENGTH OF 2 1/2" SUPPLY LINE.
- 63. TWO 250' x 1 3/4" HANDLINES WITH A 200 GPM SOF, THE TWO 1 3/4" LINES ARE WYED OFF OF A 200' LENGTH OF 2 1/2" SUPPLY LINE.

REFERENCE PAGE – 46- 47 & 48 - 49

- 64. DELUGE SET OR GROUND MONITOR WITH A 2" TIP, SUPPLIED BY THREE 400' LENGTHS OF 2 1/2".
- 65. DELUGE SET OR GROUND MONITOR WITH A 1 1/2" TIP, SUPPLIED BY TWO 500' LENGTHS OF 2 1/2".
- 66. DELUGE SET OR GROUND MONITOR WITH A 750 GPM SOF SUPPLIED BY THREE 450' LENGTHS OF 2 1/2".
- 67. DELUGE SET OR GROUND MONITOR WITH A TURBOJET 1000 GPM FOG SUPPLIED BY THREE 200' LENGTHS OF 2 1/2".

REFERENCE PAGE – 52- 53

- 68. AERIAL LADDER (NOT PRE-PLUMBED) WITH 1 3/8" TIP, AT 80' ELEVATION, SUPPLIED BY 400' OF 4", TO THE TRUCKS 100' LENGTH OF 3" HOSE.
- 69. AERIAL LADDER (NOT PRE-PLUMBED) WITH 1 1/2" TIP, AT 100' ELEVATION, SUPPLIED BY 600' OF 4", TO THE TRUCKS 100' LENGTH OF 3" HOSE.
- 70. AERIAL LADDER (NOT PRE-PLUMBED) WITH 1 3/4" TIP, AT 75' ELEVATION, SUPPLIED BY 350' OF 4", TO THE TRUCKS 100' LENGTH OF 3" HOSE.
- 71. AERIAL LADDER (NOT PRE-PLUMBED) WITH 1000 GPM low psi FOG (80psi) AT 50' ELEVATION, SUPPLIED BY 200' OF 4", TO THE TRUCKS 100' LENGTH OF 3" HOSE.

REFERENCE PAGE – 56- 57

72. PRE-PLUMBED AERIAL LADDER WITH 1 3/8" TIP, AT 100' ELEVATION, SUPPLIED BY THREE 200' LENGTHS OF 2 1/2" HOSE.
73. PRE-PLUMBED AERIAL LADDER WITH 1 1/2" TIP, AT 80' ELEVATION, SUPPLIED BY THREE 300' LENGTHS OF 2 1/2" HOSE.
74. SNORKLE WITH 1 3/4" TIP, AT 40' ELEVATION, SUPPLIED BY THREE 100' LENGTHS OF 2 1/2" HOSE.
75. SNORKLE WITH 2" TIP, AT 60' ELEVATION, SUPPLIED BY THREE 350' LENGTHS OF 2 1/2" HOSE.

REFERENCE PAGE – 60- 61

76. PRE-PLUMBED AERIAL LADDER WITH 1 1/4" TIP, AT 100' ELEVATION, SUPPLIED BY A 200' LENGTH OF 4" HOSE.
77. PRE-PLUMBED AERIAL LADDER WITH 1 1/2" TIP, AT 80' ELEVATION, SUPPLIED BY A 500' LENGTH OF 4" HOSE.
78. SNORKLE WITH 1 3/4" TIP, AT 40' ELEVATION, SUPPLIED BY A 600' LENGTH OF 4" HOSE.
79. SNORKLE WITH 2" TIP, AT 60' ELEVATION, SUPPLIED BY A 450' LENGTH OF 4" HOSE.

REFERENCE PAGE – 62- 63

80. STANDPIPE TO THE 12TH FLOOR WITH A SINGLE 1 3/4" HOSE 150' LONG FLOWING A 150 GPM SOF NOZZLE AND SUPPLIED BY TWO 200' LENGTHS OF 2 1/2" HOSE.
81. STANDPIPE TO THE 5TH FLOOR WITH TWO 1 3/4" HOSE 150' LONG FLOWING 175 GPM SOF NOZZLES AND SUPPLIED BY TWO 300' LENGTHS OF 2 1/2" HOSE.
82. STANDPIPE TO THE 9TH FLOOR WITH TWO 1 3/4" HOSE 150' LONG EACH FLOWING 125 GPM SOF NOZZLES AND SUPPLIED BY TWO 100' LENGTHS OF 2 1/2" HOSE.
83. STANDPIPE TO THE 4TH FLOOR WITH TWO 2 1/2" HOSE LINES 100' LONG EACH FLOWING 200 GPM SOF NOZZLES AND SUPPLIED BY TWO 400' LENGTHS OF 2 1/2" HOSE.

REFERENCE PAGE – 66- 67

84. SPRINKLER SYSTEM ON THE 1ST FLOOR WITH 8 HEADS FUSED. SYSTEM IS SUPPLIED BY TWO 100' LENGTHS OF 2 ½" HOSE.
85. SPRINKLER SYSTEM ON THE 14TH FLOOR WITH 12 HEADS FUSED. SYSTEM IS SUPPLIED BY TWO 200' LENGTHS OF 2 ½" HOSE.
86. SPRINKLER SYSTEM ON THE 13TH FLOOR WITH 18 HEADS FUSED. SYSTEM IS SUPPLIED BY TWO 400' LENGTHS OF 2 ½" HOSE.
87. SPRINKLER SYSTEM ON THE 10TH FLOOR WITH 20 HEADS FUSED. SYSTEM IS SUPPLIED BY TWO 250' LENGTHS OF 2 ½" HOSE.

ANSWERS TO PRACTICE HYDRAULICS PROBLEMS

#	REFERENCE PAGE	GPM	FRICTION LOSS RATE	PUMP PRESSURE	
1	12-13	125	3	118	
2	12-13	150	5	128	
3	12-13	200	8	164	
4	12-13	250	13	185	
5	14-15	120	3	62	
6	14-15	160	5	83	
7	14-15	210	9	122	
8	14-15	270	15	163	
9	16-17	125	3	148	
10	16-17	150	5	125	
11	16-17	200	8	192	
12	16-17	250	13	261	
13	18-19	125	3	87	
14	18-19	150	5	78	
15	18-19	200	8	93	
16	18-19	250	13	157	
17	20-21	30	1	106	
18	20-21	60	3	111	
19	20-21	95	7	121	
20	20-21	125	13	113	
21	20-21	150	18	226	
22	20-21	175	25	213	
23	20-21	200	32	244	
24	22-23	125	13	159	178
25	22-23	150 200	18 32	118	164
26	22-23	125	13	159	178
27	22-23	60 200	3 32	103	212
28	24-25	30	1	102	105
29	24-25	60	3	103	109
30	24-25	125	13	126	172
31	24-25	150	18	163	226

FIREGROUND HYDRAULICS

#	REFERENCE PAGE	GPM		FRICTION LOSS RATE		PUMP PRESSURE
32	26-27	7		1		56
33	26-27	13		1		60
34	26-27	30		2		69
35	26-27	50		6		95
36	28-29	5		1		102
37	28-29	10		1		104
38	28-29	20		6		118
39	28-29	40		26		126
40	30-31	5		1	3	106
41	30-31	10		1	13	121
42	30-31	40		26	200	426
Max hose pressure = 400 lbs.						
43	32-33	270		4	15	98
44	32-33	250		3	13	150
45	32-33	210		2	9	74
46	32-33	120		1	3	65
47	34-35	270		15	4	85
48	34-35	200		2	8	128
49	36-37 & 42-43	150	150	5	18	147
50	36-37 & 42-43	175	175	6	25	187
51	36-37 & 42-43	210	210	9	35	165
52	36-37 & 42-43	270	270	15	58	138
53	38-39	150	150	5	18	133
54	38-39	175	175	6	25	184
55	38-39	120	120	3	12	94
56	38-39	200	200	8	32	152
57	40-41	210	270	15	46	141
58	40-41	150	250	13	32	248
59	40-41	120	210	9	22	137
60	44-45	60	60	3	3	121
61	44-45	175	175	25	25	288
62	44-45	125	125	13	13	198
63	44-45	200	200	32	32	244

FIREGROUND HYDRAULICS

#	REFERENC E PAGE	GPM		FRICTION LOSS RATE		PUMP PRESSURE
64	46-47 & 48-49	1100		27		203
65	46-47 & 48-49	600		18		185
66	46-47 & 48-49	750		13		174
67	46-47 & 48-49	1000		23		161
68	52-53	500		3	23	170
69	52-53	600		5	32	207
70	52-53	800		8	58	219
71	52-53	1000		13	90	236
72	56-57	500		6		167
73	56-57	600		8		169
74	56-57	800		15		140
75	56-57	1100		27		230
76	60-61	400		2		159
77	60-61	600		5		170
78	60-61	800		8		173
79	60-61	1100		16		207
80	62-63	150		1	18	209
81	62-63	175	175	6	25	201
82	62-63	125	125	3	13	188
83	62-63	200	200	8	8	180
84	66-67	240		3		58
85	66-67	360		6		132
86	66-67	540		15		175
87	66-67	600		18		145

